

MODEL	RATED TORQUE @ STD. AIR GAP		BREAKAWAY TORQUE		MAX RPM
MTD-8	7.5 Nm	66 Lb-in	8.5 Nm	75 Lb-in	10,500*

* BALANCING FOR HIGH SPEED APPLICATIONS REQUIRED

REVISIONS			
REV.	ECN.	DESCRIPTION	DATE

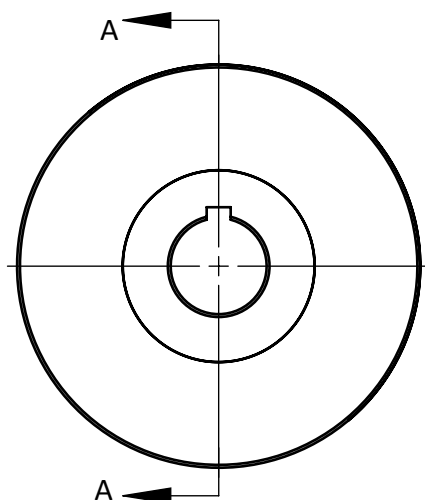
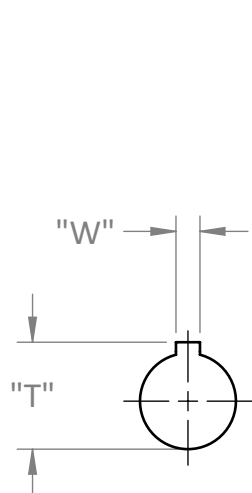

COUPLING HALF:
WEIGHT: 2.55 Lbs (1.16 Kg)

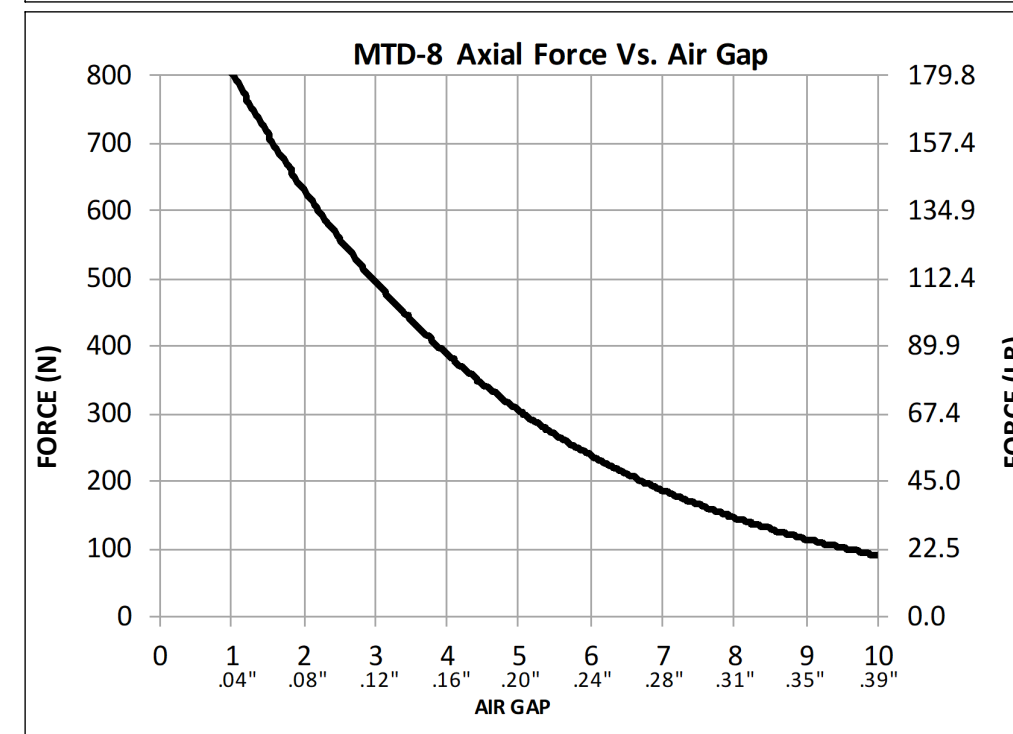
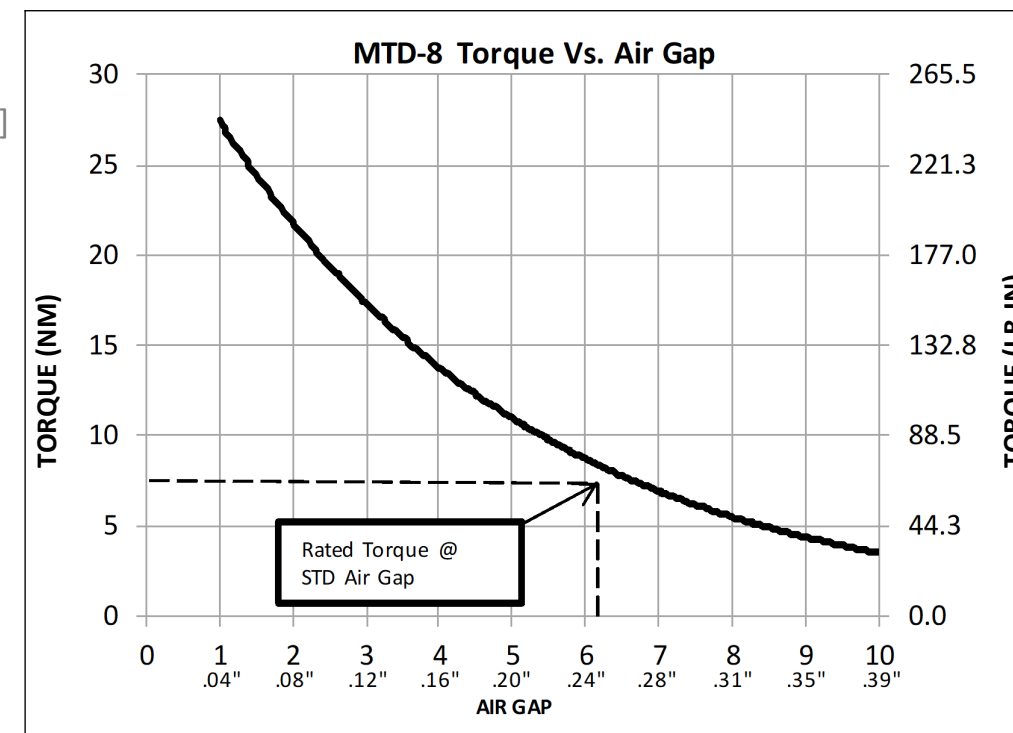
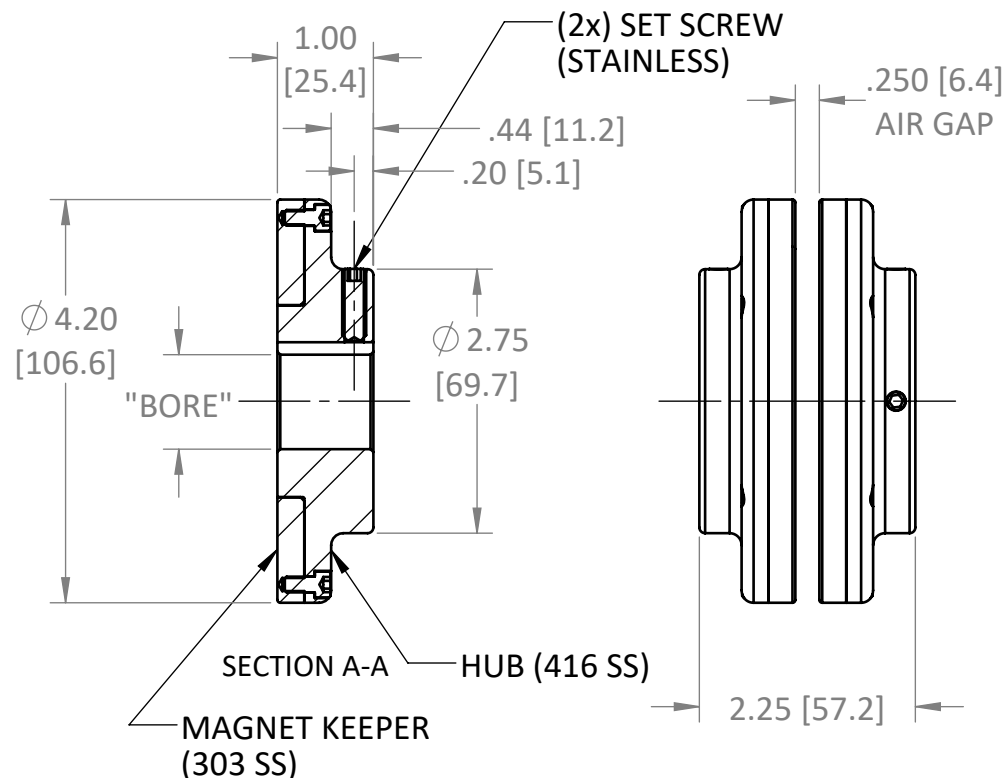

MODEL	BORE		W		T		SET SCREW (2x)
	mm ^{H8}	in ^{+0.001}	mm ^{+0.05}	in ^{+0.002}	mm ^{+0.25}	in ^{+0.010}	CUP POINT
* MTD-8-0000	SOLID		-		-		-
MTD-8-0500	12.70	.500	3.18	.1250	14.22	.560	#10-32 x 3/4
MTD-8-0551	14.00	.551	5.00	.1969	16.30	.642	M5-0.8 x 20 mm
MTD-8-0625	15.88	.625	4.76	.1875	18.00	.709	#10-32 x 3/4
MTD-8-0748	19.00	.748	6.00	.2362	21.80	.858	M5-0.8 x 20 mm
MTD-8-0750	19.05	.750	4.76	.1875	21.26	.837	#10-32 x 3/4
MTD-8-0875	22.23	.875	4.76	.1875	24.49	.964	#10-32 x 3/4
MTD-8-0945	24.00	.945	8.00	.3150	27.30	1.075	M8 -1.25 x 20 mm
MTD-8-0100	25.40	1.000	6.35	.2500	28.30	1.114	1/4-20 x 5/8
MTD-8-0110	28.00	1.102	8.00	.3150	31.30	1.232	M8-1.25 x 20 mm
MTD-8-0112	28.56	1.125	6.35	.2500	31.52	1.241	1/4-20 x 5/8
MTD-8-0125	31.75	1.250	6.35	.2500	34.72	1.367	1/4-20 x 5/8
MTD-8-0137	34.93	1.375	7.94	.3125	38.56	1.518	5/16-18 x 1/2

OTHER SIZES AVAILABLE; SPECIFY BOTH BORE AND KEYWAY

*** ONLY MTD-8-0000 FROM STOCK**

THIS DRAWING IS THE PROPERTY OF MAGNETIC TECHNOLOGIES LTD. AND IS SUPPLIED ON THE EXPRESS CONDITION THAT IT SHALL NOT BE LENT, COPIED, REPRODUCED NO DISCLOSED TO ANY OTHER PERSON, IN WHOLE OR IN PART WITHOUT THE WRITTEN CONSENT OF MAGNETIC TECHNOLOGIES LTD.

USED ON MTD-8	SCALE 1:2	MATERIAL SEE PRT DWG	MAGNETIC TECHNOLOGIES LTD. 43 TOWN FOREST ROAD OXFORD, MA 01540
UNLESS OTHERWISE SPECIFIED: ALL DIMENSIONS ARE IN INCHES TOLERANCES: DECIMAL: .XX ± .01 .XXX ± .005 ANGULAR: ± 1° GEN. CONCENTRICITY: .001 T.I.R. MACH. FILLETS: .010 R MACH. EDGES: .015 R OR CHMF. UNSPECIFIED RADII: .015 R IN MICROINCHES RMS 32 GEOMETRIC: TO MIL-ST'D. 8 REMOVE ALL BURRS & SHARP EDGES		FINISH SEE PRT DWG	
		DRAWN AMD 11/11/14	DESCRIPTION MTD-8 Cut Sheet
		CHECKED ASM 1/4/2022	DWG. NO. _____ REV. _____
		SIZE: B	MTD-8-XXX