

MODEL	RATED TORQUE @ STD. AIR GAP		BREAKAWAY TORQUE		MAX RPM
MTD-30	25.4 Nm	225 Lb-in	27.7 Nm	245 Lb-in	9,200*

\* BALANCING FOR HIGH SPEED APPLICATIONS REQUIRED

REVISIONS			
REV.	ECN.	DESCRIPTION	DATE

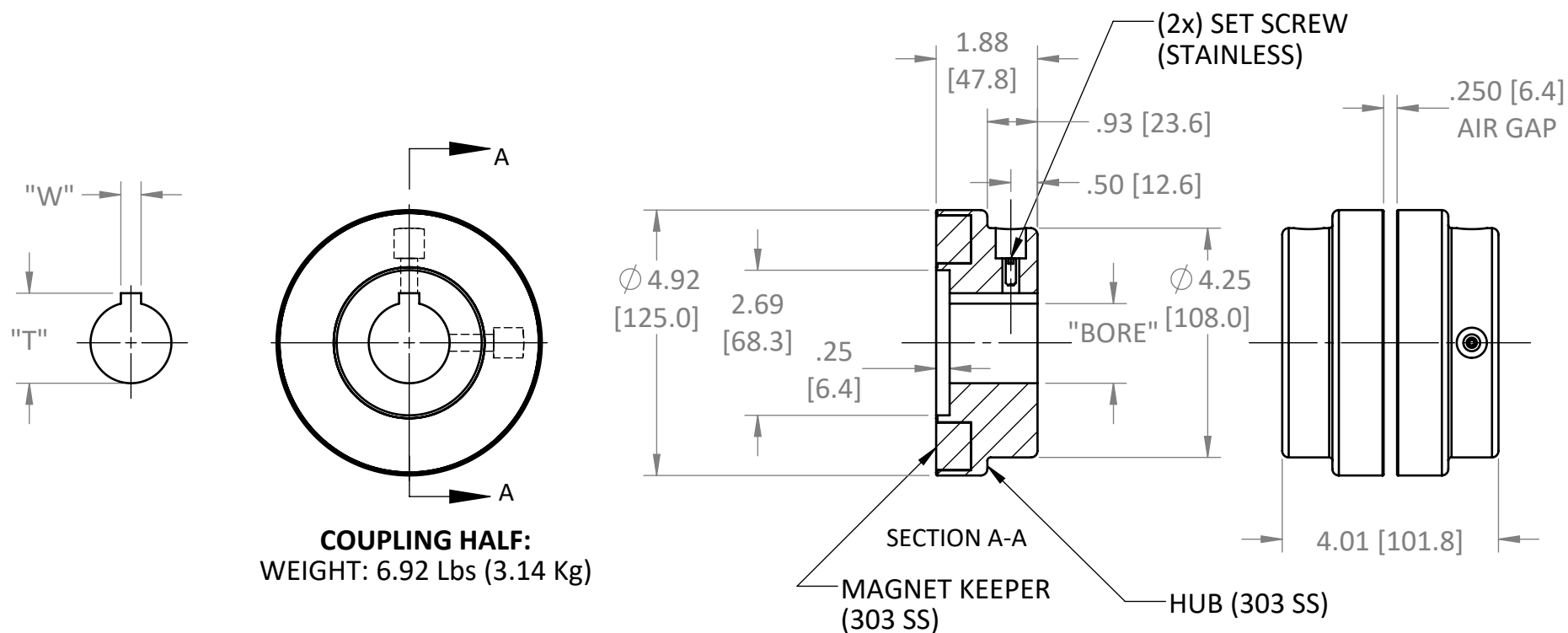

**COUPLING HALF:**  
WEIGHT: 6.92 Lbs (3.14 Kg)

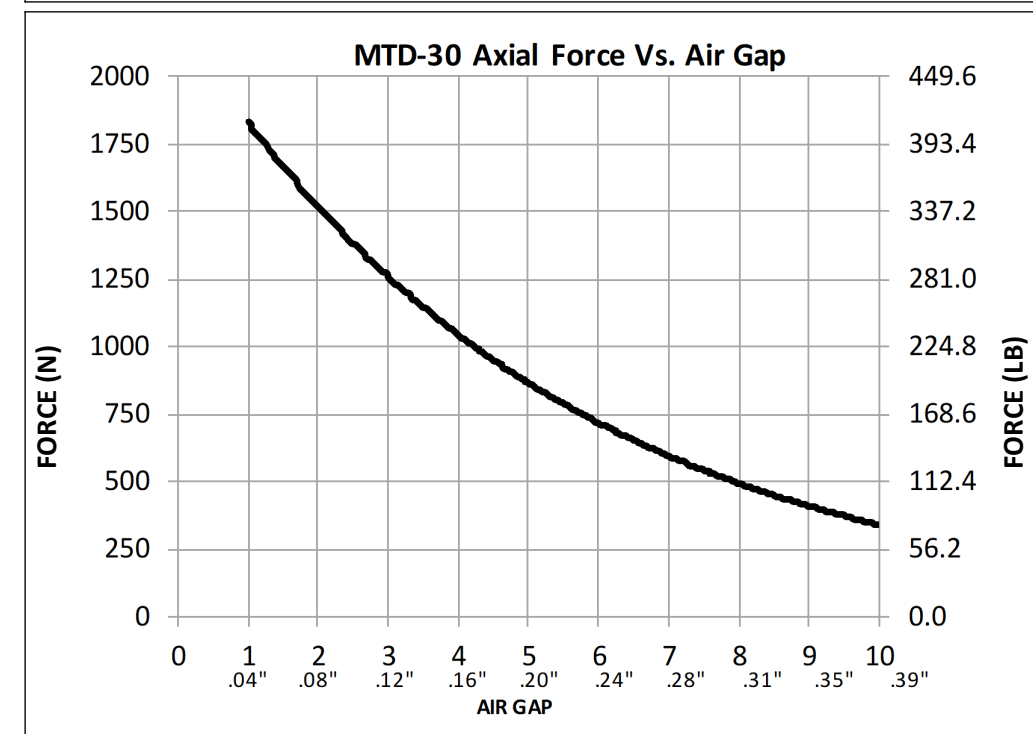
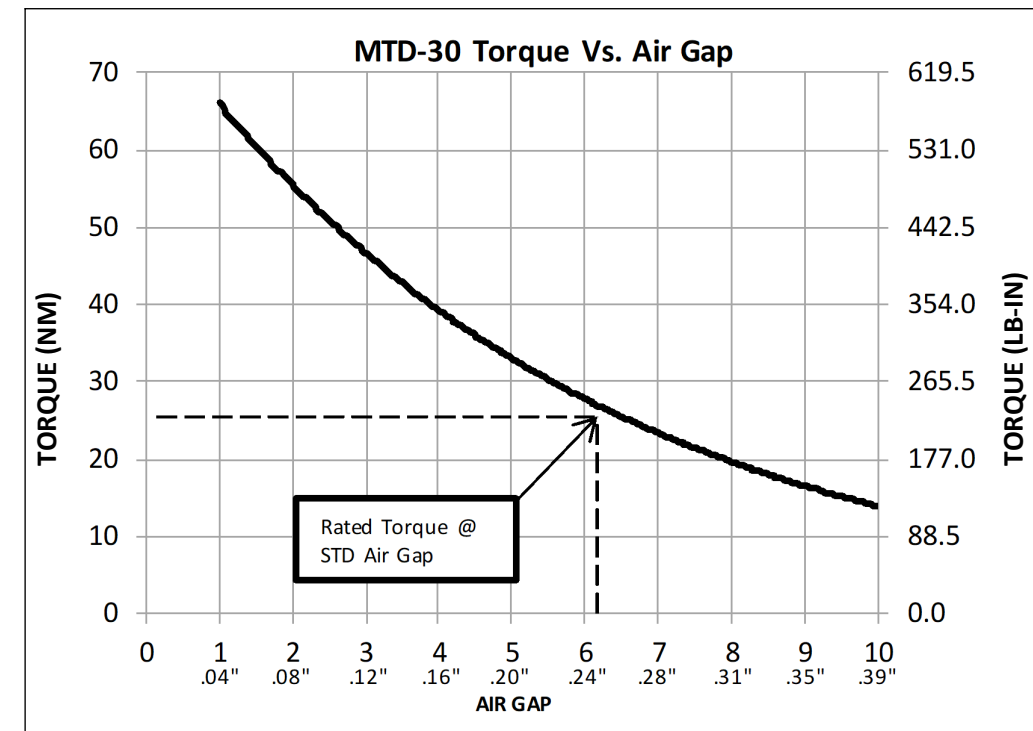

\*

MODEL	BORE		W		T		SET SCREW (2x)
	mm <sup>H8</sup>	in <sup>+0.01</sup>	mm <sup>+0.05</sup>	in <sup>+0.002</sup>	mm <sup>+0.25</sup>	in <sup>+0.010</sup>	CUP POINT
MTD-30-0000	SOLID		-	-	-	-	-
MTD-20-0875	22.23	.875	-	-	-	-	-
MTD-20-01000	25.40	1.000	6.35	.250	28.30	1.114	1/4-20 X 1
MTD-20-01125	28.56	1.125	6.35	.250	31.52	1.241	1/4-20 X 1
MTD-20-01250	31.75	1.250	6.35	.250	34.72	1.367	1/4-20 X 3/4
MTD-20-01375	34.93	1.375	7.94	.3125	38.56	1.518	5/16-18 X 3/4
MTD-20-01500	38.10	1.500	9.53	.375	42.39	1.669	3/8-16 X 5/8
MTD-20-01625	41.28	1.625	9.53	.375	45.62	1.796	3/8-16 X 5/8
MTD-30-01750	44.45	1.750	9.53	.375	48.82	1.922	3/8-16 X 5/8
MTD-30-01875	47.63	1.875	12.70	.500	52.24	2.096	1/2-13 x 1/2
MTD-30-02000	50.80	2.000	12.70	.500	56.46	2.223	1/2-13 x 1/2
MTD-30-02125	53.98	2.125	12.70	.500	56.69	2.350	1/2-13 x 1/2

OTHER SIZES AVAILABLE; SPECIFY BOTH BORE AND KEYWAY

**\* ONLY MTD-30-0000 FROM STOCK**

THIS DRAWING IS THE PROPERTY OF MAGNETIC TECHNOLOGIES LTD. AND IS SUPPLIED ON THE EXPRESS CONDITION THAT IT SHALL NOT BE LENT, COPIED, REPRODUCED NO DISCLOSED TO ANY OTHER PERSON, IN WHOLE OR IN PART WITHOUT THE WRITTEN CONSENT OF MAGNETIC TECHNOLOGIES LTD.

USED ON MTD-30	SCALE 1:2	MATERIAL SEE PRT DWG	<b>MAGNETIC TECHNOLOGIES LTD.</b> 43 TOWN FOREST ROAD OXFORD, MA 01540
UNLESS OTHERWISE SPECIFIED: ALL DIMENSIONS ARE IN INCHES TOLERANCES: DECIMAL: .XX ± .01 .XXX ± .005 ANGULAR: ± 1° GEN. CONCENTRICITY: .001 T.I.R. MACH. FILLETS: .010 R MACH. EDGES: .015 R OR CHMF. UNSPECIFIED RADII: .015 R IN MICROINCHES RMS 32 GEOMETRIC: TO MIL-ST'D. 8 REMOVE ALL BURRS & SHARP EDGES		FINISH SEE PRT DWG	
DRAWN AMD 11/11/14		CHECKED ASM 1/4/2022	DESCRIPTION <b>MTD-30 Cut Sheet</b>
SIZE: B			DWG. NO. _____ REV. _____
			<b>MTD-30-XXX</b>