

MODEL	RATED TORQUE @ STD. AIR GAP	BREAKAWAY TORQUE	MAX RPM
MTD-0.3	0.45 Nm	4 Lb-in	26,000*

* BALANCING FOR HIGH SPEED APPLICATIONS REQUIRED

REVISIONS			
REV.	ECN.	DESCRIPTION	DATE

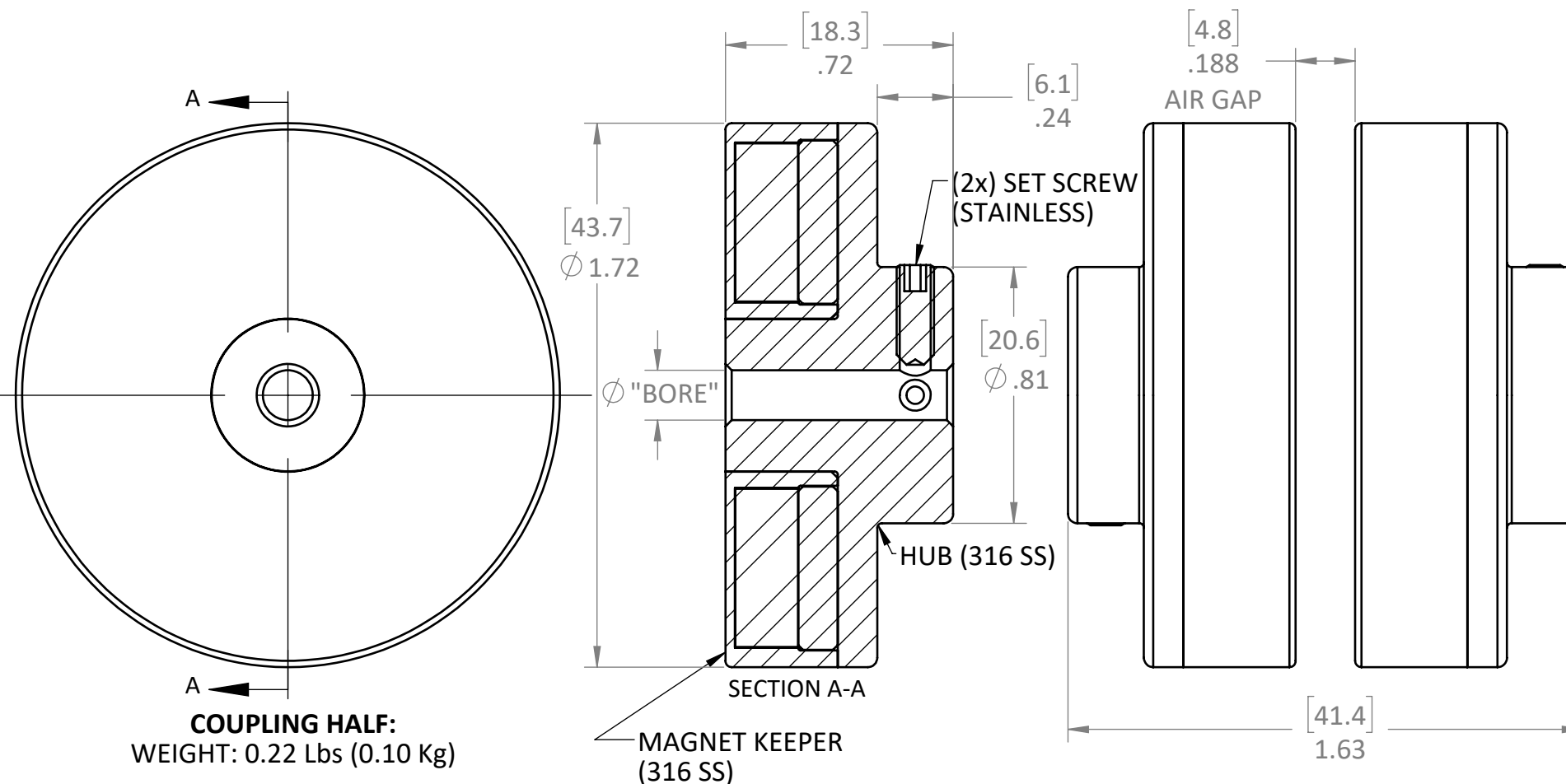

COUPLING HALF:
WEIGHT: 0.22 Lbs (0.10 Kg)

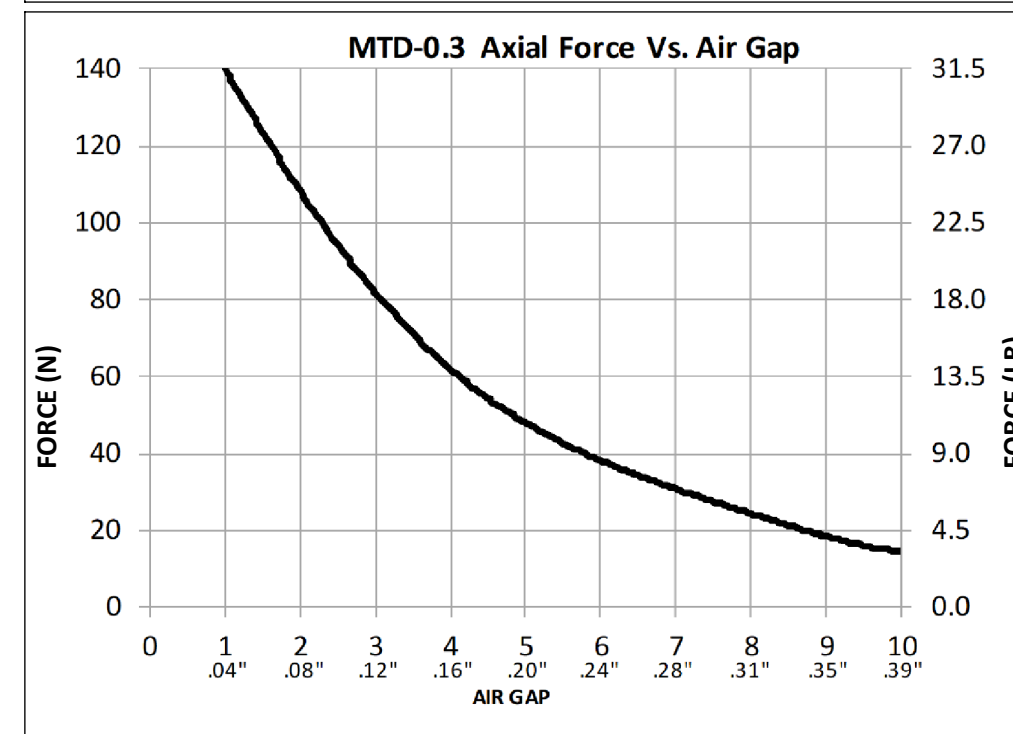
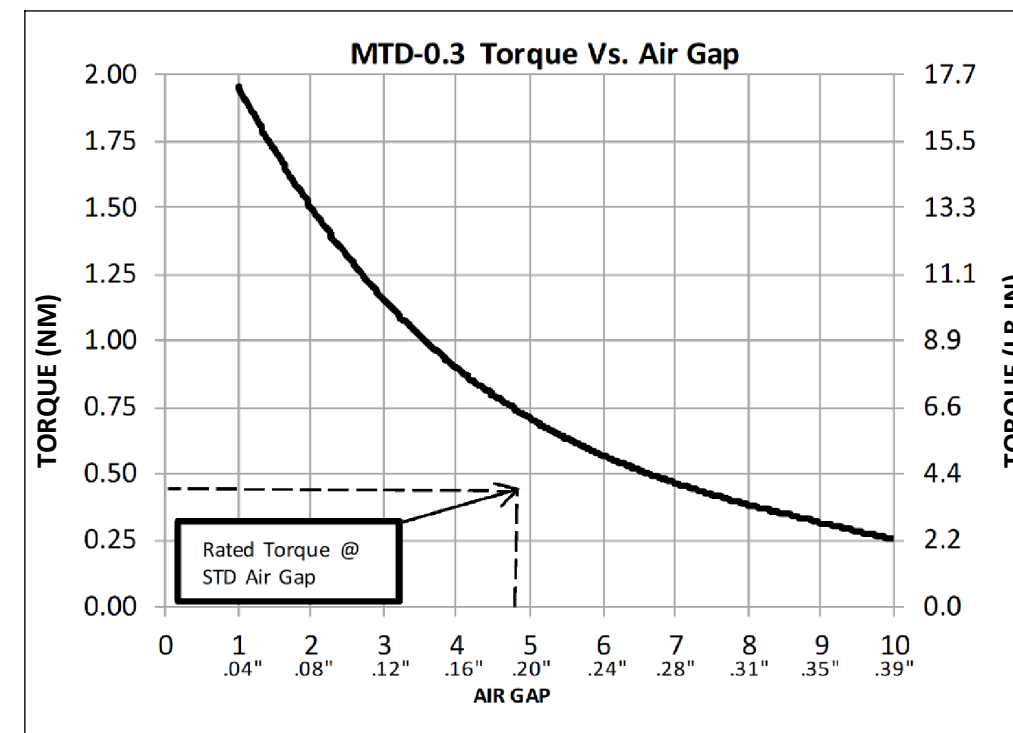

MODEL	BORE		SET SCREW (2x)
	mm ^{H8}	in ^{+0.001}	CUP POINT
MTD-0.3-019	SOLID		-
MTD-0.3-005	4.76	.1875	#8-32 X 1/4
MTD-0.3-022	5.00	.197	M4-0.7 x 6mm
MTD-0.3-018	6.35	.250	#8-32 X 1/4
MTD-0.3-035	8.00	.315	M4-0.7 x 6mm
MTD-0.3-030	9.53	.375	#8-32 X 1/4

OTHER SIZES AVAILABLE; SPECIFY BORE

USED ON MTD-0.3	SCALE 2:1	MATERIAL SEE PRT DWG	 43 TOWN FOREST ROAD OXFORD, MA 01540
UNLESS OTHERWISE SPECIFIED:		FINISH SEE PRT DWG	
ALL DIMENSIONS ARE IN INCHES TOLERANCES: DECIMAL: .XX ± .01 .XXX ± .005 ANGULAR: ± 1° GEN. CONCENTRICITY: .001 T.I.R. MACH. FILLETS: .010 R MACH. EDGES: .015 R OR CHMF. UNSPECIFIED RADII: .015 R IN MICROINCHES RMS 32 GEOMETRIC: TO MIL-ST'D. 8 REMOVE ALL BURRS & SHARP EDGES			DRAWN ASM 9/1/2022 CHECKED
DESCRIPTION MTD-0.3 (316) Cut Sheet DWG. NO. _____ REV. _____ MTD-0.3-XXX (316)			SIZE: B