

MTC-30	RATED TORQUE	SLIP TORQUE	MAX SPEED	WEIGHT
	30 Nm	48 Nm	9,400 RPM *	8 kg.
	265 LB-IN	425 LB-IN		18 lbs.

* BALANCING FOR HIGH SPEED APPLICATIONS REQUIRED

REVISIONS			
REV.	ECN.	DESCRIPTION	DATE

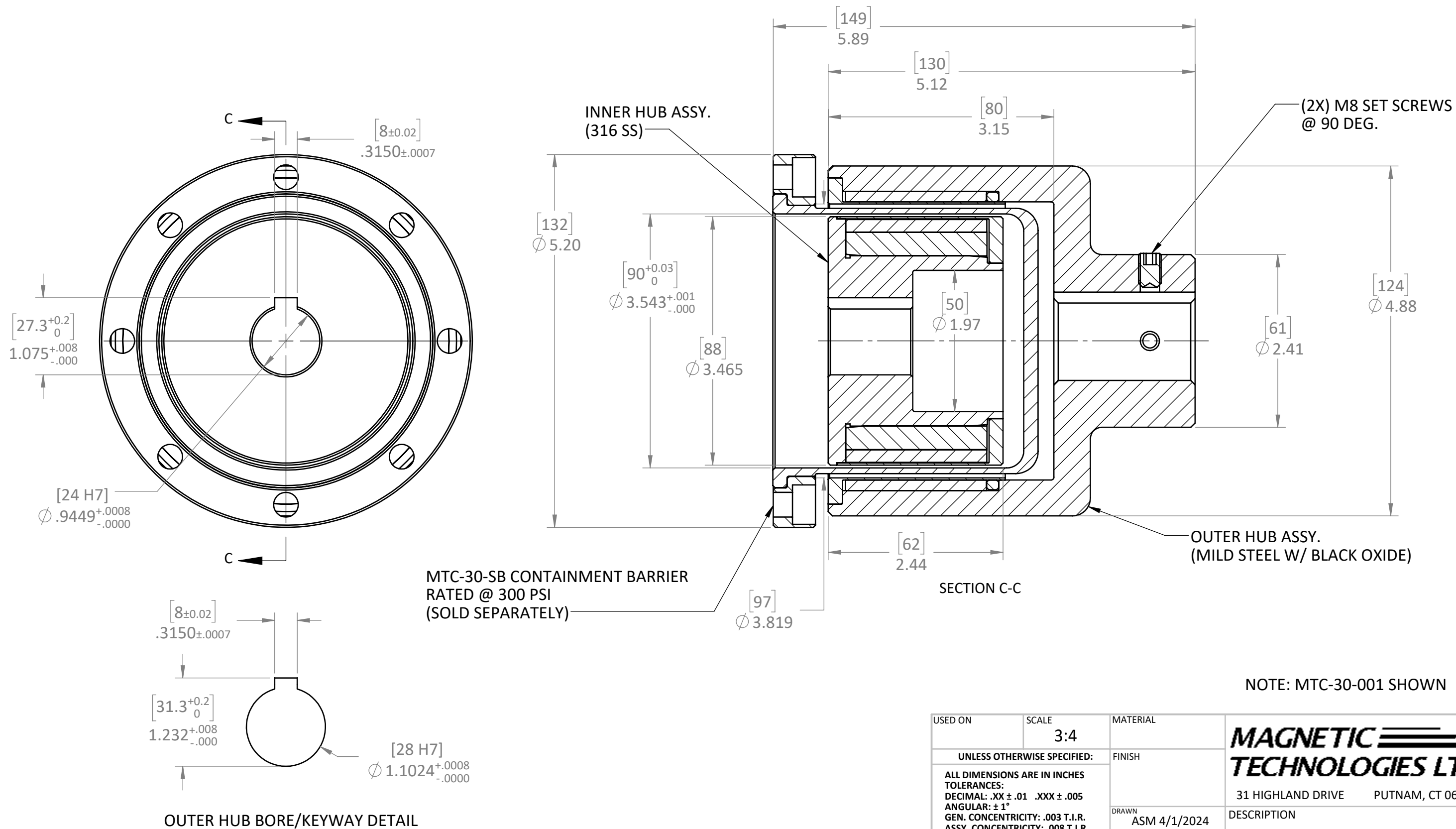

NOTE: MTC-30-001 SHOWN

THIS DRAWING IS THE PROPERTY OF MAGNETIC TECHNOLOGIES LTD. AND IS SUPPLIED ON THE EXPRESS CONDITION THAT IT SHALL NOT BE LENT, COPIED, REPRODUCED NOR DISCLOSED TO ANY OTHER PERSON, IN WHOLE OR IN PART WITHOUT THE WRITTEN CONSENT OF MAGNETIC TECHNOLOGIES LTD.

USED ON	SCALE 3:4	MATERIAL	MAGNETIC TECHNOLOGIES LTD 31 HIGHLAND DRIVE PUTNAM, CT 06260
UNLESS OTHERWISE SPECIFIED:		FINISH	
ALL DIMENSIONS ARE IN INCHES TOLERANCES: DECIMAL: .XX ± .01 .XXX ± .005 ANGULAR: ± 1° GEN. CONCENTRICITY: .003 T.I.R. ASSY. CONCENTRICITY: .008 T.I.R. MACH. FILLETS: .010 R MACH. EDGES: .015 R OR CHMF. UNSPECIFIED RADII: .015 R IN MICROINCHES RMS 32 GEOMETRIC: TO MIL-ST'D. 8 REMOVE ALL BURRS & SHARP EDGES		DRAWN ASM 4/1/2024	DESCRIPTION 30 Nm COUPLING
		CHECKED	DWG. NO. REV.
		SIZE: B	MTC-30 CUT SHEET