

MODEL NO.	VOLTAGE (Vdc)	RATED CURRENT (mA)	MIN. TORQUE AT RATED CURRENT	RESISTANCE ±10% @ 25° (OHMS)	NOMINAL POWER (WATTS)	MAX SPEED (RPM)	POWER RATING (WATTS) 5 MINUTES	POWER RATING (WATTS) CONTINUOUS	RESIDUAL TORQUE @ 1000 RPM	ROTOR INERTIA	ANGULAR ACCELERATION (rad / s^2)	WEIGHT	REVISIONS			
													REV.	ECN.	DESCRIPTION	DATE
EB-20	24	232	21.2 oz-in	120	5.65	20,000*	50	12	110 x 10^-3	40.53 x 10^-6 lb-in sec^2	33,000	.71 lb				
EB-20	24	232	.15 Nm	120	5.65	20,000*	50	12	777 x 10^-6 Nm	.0458 kg cm^2	33,000	.32 kg				

* BALANCING FOR HIGH SPEED APPLICATIONS REQUIRED

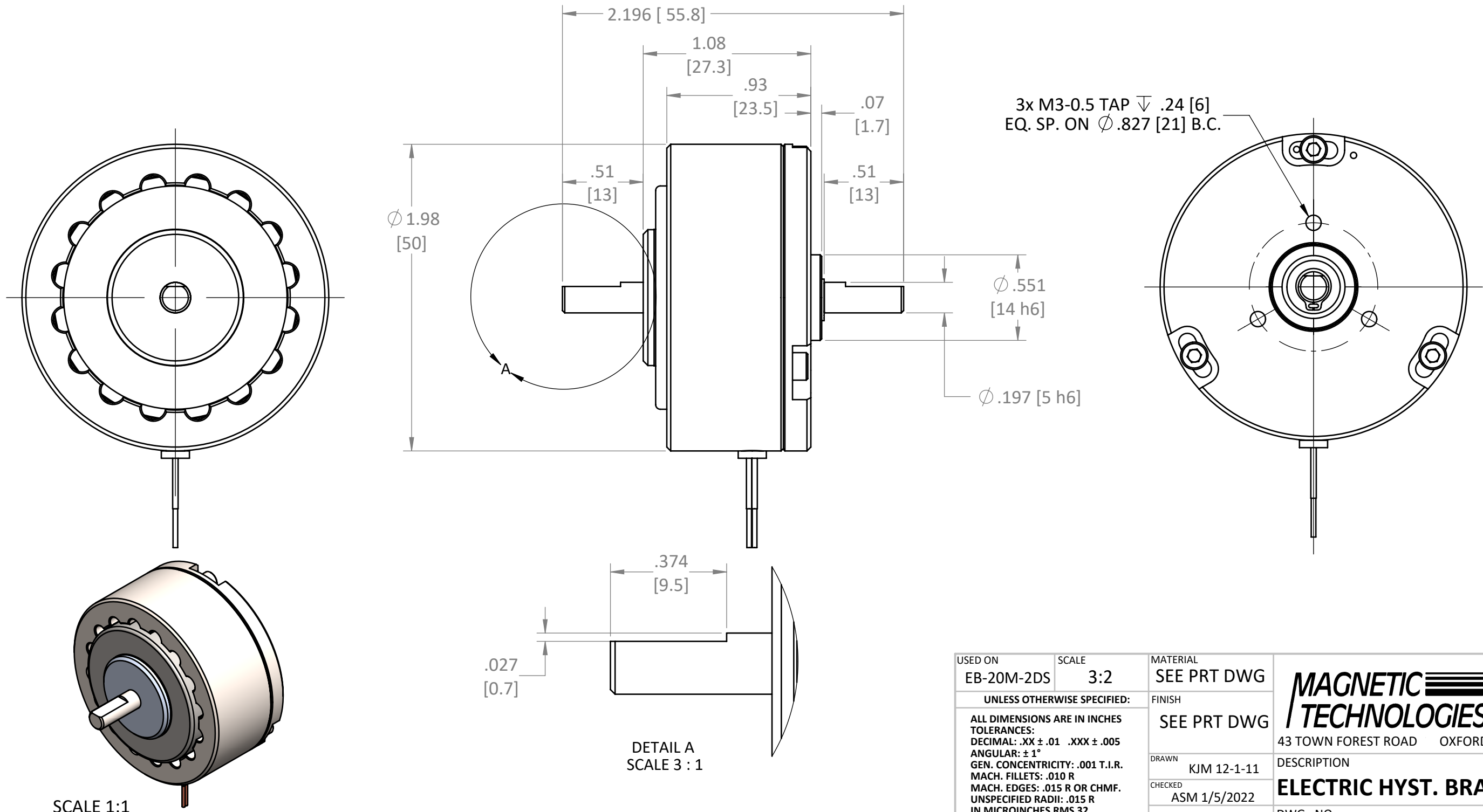

THIS DRAWING IS THE PROPERTY OF MAGNETIC TECHNOLOGIES LTD. AND IS SUPPLIED ON THE EXPRESS CONDITION THAT IT SHALL NOT BE LENT, COPIED, REPRODUCED NO DISCLOSED TO ANY OTHER PERSON, IN WHOLE OR IN PART WITHOUT THE WRITTEN CONSENT OF MAGNETIC TECHNOLOGIES LTD.

USED ON EB-20M-2DS	SCALE 3:2	MATERIAL SEE PRT DWG	MAGNETIC TECHNOLOGIES LTD. 43 TOWN FOREST ROAD OXFORD, MA 01540
UNLESS OTHERWISE SPECIFIED: ALL DIMENSIONS ARE IN INCHES TOLERANCES: DECIMAL: .XX ± .01 .XXX ± .005 ANGULAR: ± 1° GEN. CONCENTRICITY: .001 T.I.R. MACH. FILLETS: .010 R MACH. EDGES: .015 R OR CHMF. UNSPECIFIED RADII: .015 R IN MICROINCHES RMS 32 GEOMETRIC: TO MIL-ST'D. 8 REMOVE ALL BURRS & SHARP EDGES		FINISH SEE PRT DWG	
		DRAWN KJM 12-1-11	DESCRIPTION ELECTRIC HYST. BRAKE
		CHECKED ASM 1/5/2022	DWG. NO. EB-20M-2DS
		SIZE: B	REV.

EB-20M-2DS ELECTRIC HYSTERESIS BRAKE

TORQUE VS. CURRENT

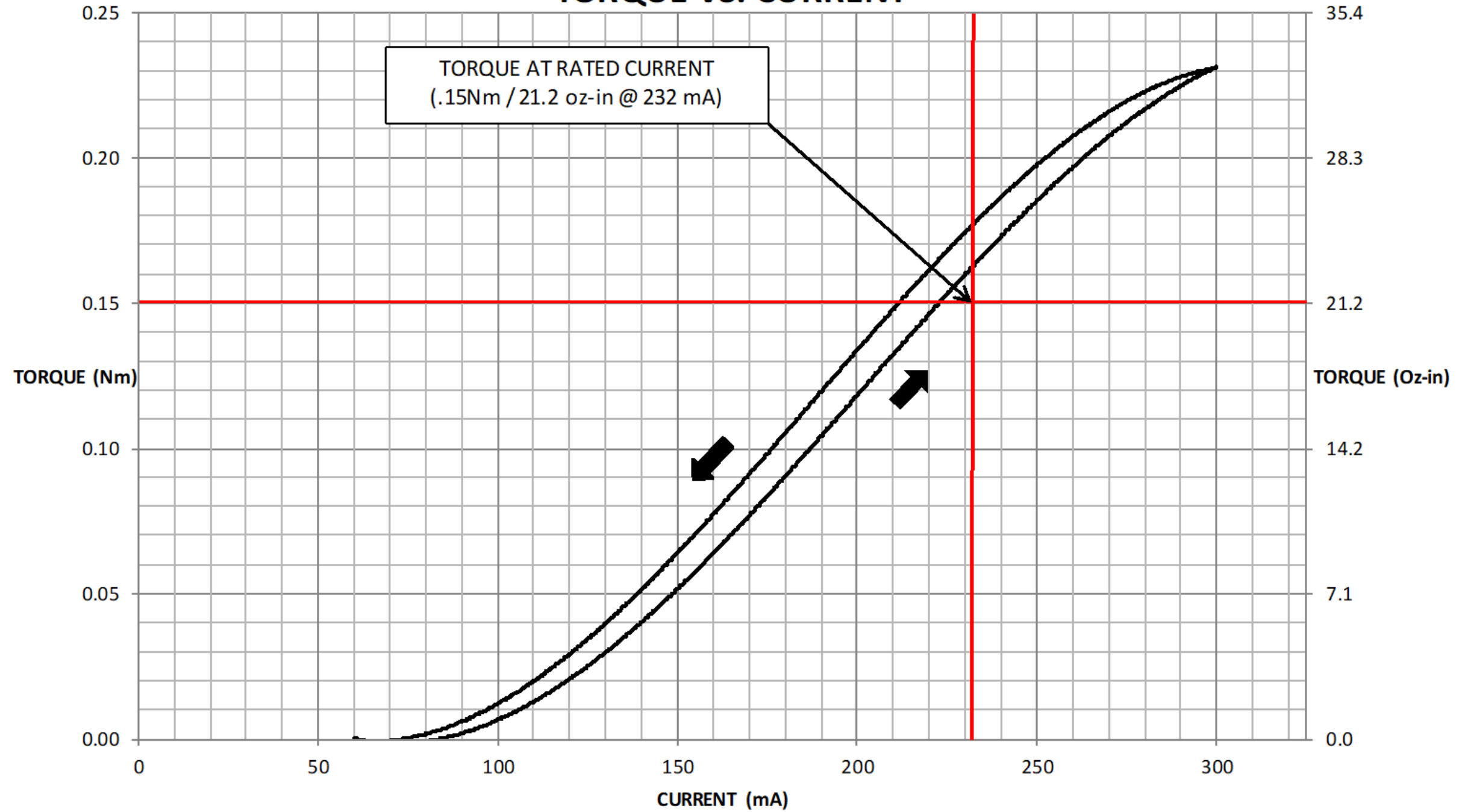

NOTE:

1. ACTUAL CURVE MAY VARY. THE TORQUE AT THE RATED CURRENT IS THE MINIMUM GUARANTEED TORQUE AT THAT CURRENT. TYPICAL BRAKES CAN BE 10-25% OVER RATED TORQUE, BUT THOSE RESULTS ARE **NOT** GUARANTEED.

THIS DRAWING IS THE PROPERTY OF MAGNETIC TECHNOLOGIES LTD. AND IS SUPPLIED ON THE EXPRESS CONDITION THAT IT SHALL NOT BE LENT, COPIED, REPRODUCED NO DISCLOSED TO ANY OTHER PERSON, IN WHOLE OR IN PART WITHOUT THE WRITTEN CONSENT OF MAGNETIC TECHNOLOGIES LTD.

USED ON EB-20M-2DS	SCALE	MATERIAL	 43 TOWN FOREST ROAD OXFORD, MA 01540
UNLESS OTHERWISE SPECIFIED: ALL DIMENSIONS ARE IN INCHES TOLERANCES: DECIMAL: .XX ± .01 .XXX ± .005 ANGULAR: ± 1° GEN. CONCENTRICITY: .001 T.I.R. MACH. FILLETS: .010 R MACH. EDGES: .015 R OR CHMF. UNSPECIFIED RADII: .015 R IN MICROINCHES RMS 32 GEOMETRIC: TO MIL-ST'D. 8 REMOVE ALL BURRS & SHARP EDGES			
			TECHNICAL DATA DWG. NO. REV. EB-20M-2DS
WEIGHT:		SIZE: B	