

MODEL NO.	VOLTAGE (Vdc)	RATED CURRENT (mA)	MIN. TORQUE AT RATED CURRENT	RESISTANCE ±10% @ 25°C (OHMS)	NOMINAL POWER (WATTS)	MAX SPEED (RPM)	POWER RATING (WATTS) 5 MINUTES	POWER RATING (WATTS) CONTINUOUS	RESIDUAL TORQUE @ 1000 RPM (Nm)	ROTOR INERTIA	ANGULAR ACCELERATION (rad / s ²)	WEIGHT
EB-1750	24	535	2053.3 oz-in	52	13	6,000*	1,200	350	13 oz-in	55.3 x 10 ⁻³ lb-in sec ²	2,300	53.9 lb
EB-1750	24	535	14.50 Nm	52	13	6,000*	1,200	350	.0918 Nm	62.5 kg cm ²	2,300	24.5 kg

REVISIONS			
REV.	ECN.	DESCRIPTION	DATE

* BALANCING FOR HIGH SPEED APPLICATIONS REQUIRED

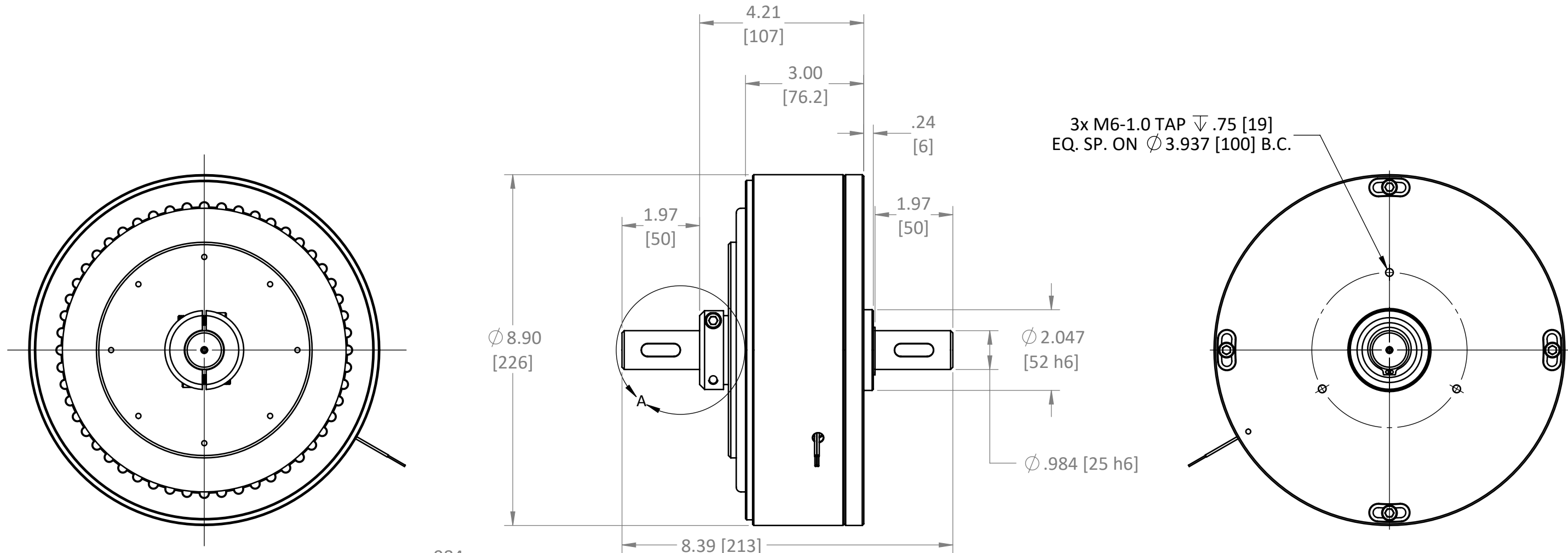

3x M6-1.0 TAP ∇.75 [19]
EQ. SP. ON Ø 3.937 [100] B.C.

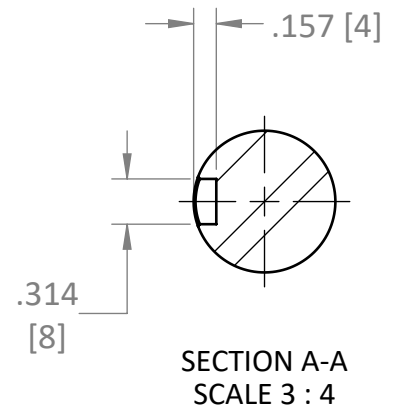
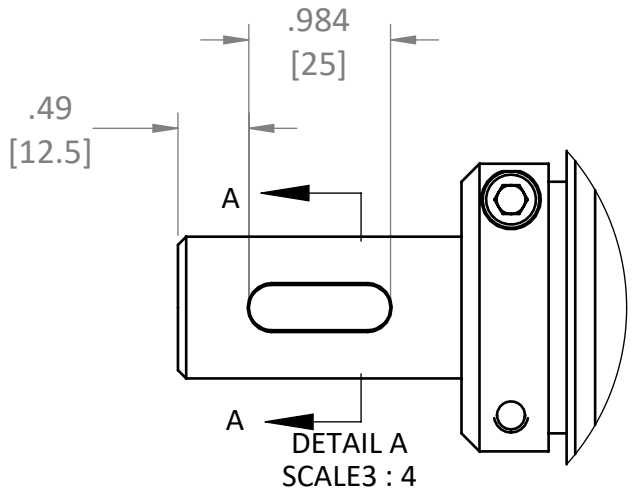

USED ON EB-1750M-2DS	SCALE 3:8	MATERIAL SEE PRT DWG	 43 TOWN FOREST ROAD OXFORD, MA 01540
UNLESS OTHERWISE SPECIFIED: ALL DIMENSIONS ARE IN INCHES TOLERANCES: DECIMAL: .XX ± .01 .XXX ± .005 ANGULAR: ± 1° GEN. CONCENTRICITY: .001 T.I.R. MACH. FILLETS: .010 R MACH. EDGES: .015 R OR CHMF. UNSPECIFIED RADII: .015 R IN MICROINCHES RMS 32 GEOMETRIC: TO MIL-ST'D. 8 REMOVE ALL BURRS & SHARP EDGES		FINISH SEE PRT DWG	
DRAWN KJM 12-6-11		CHECKED ASM 1/6/2022	DESCRIPTION ELECTRIC HYST. BRAKE
SIZE: B			DWG. NO. EB-1750M-2DS REV.

THIS DRAWING IS THE PROPERTY OF MAGNETIC TECHNOLOGIES LTD. AND IS SUPPLIED ON THE EXPRESS CONDITION THAT IT SHALL NOT BE LENT, COPIED, REPRODUCED NO DISCLOSED TO ANY OTHER PERSON, IN WHOLE OR IN PART WITHOUT THE WRITTEN CONSENT OF MAGNETIC TECHNOLOGIES LTD.

EB-1750M-2DS ELECTRIC HYSTERESIS BRAKE TORQUE VS. CURRENT

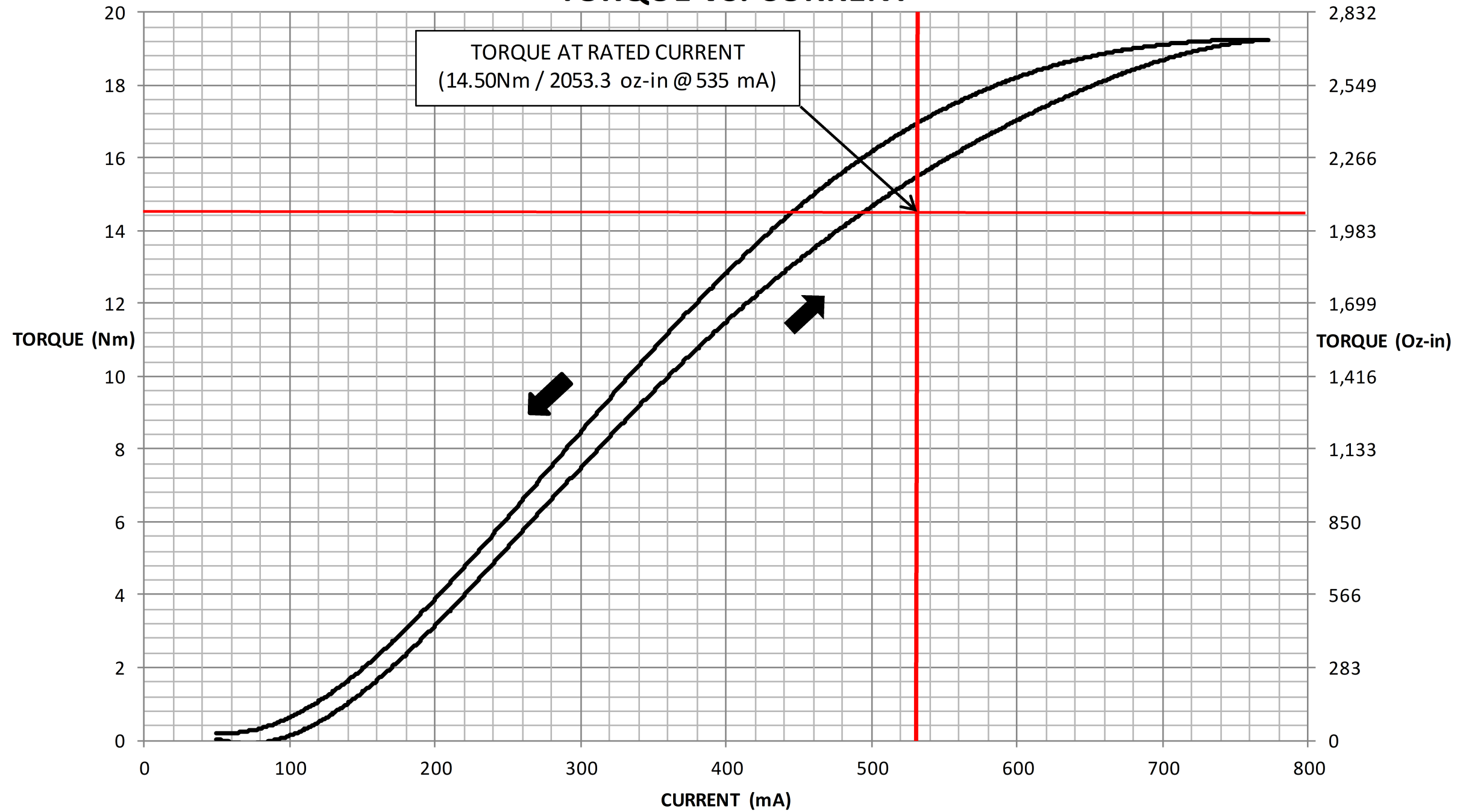

NOTE:

- ACTUAL CURVE MAY VARY. THE TORQUE AT THE RATED CURRENT IS THE MINIMUM GUARANTEED TORQUE AT THAT CURRENT. TYPICAL BRAKES CAN BE 10-25% OVER RATED TORQUE, BUT THOSE RESULTS ARE **NOT** GUARANTEED.

THIS DRAWING IS THE PROPERTY OF MAGNETIC TECHNOLOGIES LTD. AND IS SUPPLIED ON THE EXPRESS CONDITION THAT IT SHALL NOT BE LENT, COPIED, REPRODUCED NO DISCLOSED TO ANY OTHER PERSON, IN WHOLE OR IN PART WITHOUT THE WRITTEN CONSENT OF MAGNETIC TECHNOLOGIES LTD.

USED ON EB-1750M-2DS	SCALE	MATERIAL	
UNLESS OTHERWISE SPECIFIED: ALL DIMENSIONS ARE IN INCHES TOLERANCES: DECIMAL: .XX ± .01 .XXX ± .005 ANGULAR: ± 1° GEN. CONCENTRICITY: .001 T.I.R. MACH. FILLETS: .010 R MACH. EDGES: .015 R OR CHMF. UNSPECIFIED RADII: .015 R IN MICROINCHES RMS 32 GEOMETRIC: TO MIL-ST'D. 8 REMOVE ALL BURRS & SHARP EDGES			
		FINISH	43 TOWN FOREST ROAD OXFORD, MA 01540
		DRAWN KJM 1-13-12	DESCRIPTION
		CHECKED ASM 1/6/2022	TECHNICAL DATA
		WEIGHT:	DWG. NO.
		SIZE: B	REV.
			EB-1750M-2DS