

# Permanent Magnet Hysteresis Brakes & Clutches



- **Non-electrical**
- **No wearing parts**
- **Precise, permanent tension control**

**TRANSMITTING TORQUE THROUGH AIR**

## Why Mag Tech Brakes & Clutches are Better

- No electricity
- No break-away torque
- Constant torque independent of shaft (rotor) speed
- No contacting or wearing parts
- No friction elements — same smooth torque year after year
- No magnetic particles to leak or contaminate end product
- Operable in some of the most difficult environments
- Brake (with shaft) and clutch (with hollow shaft) available
- Custom designs available

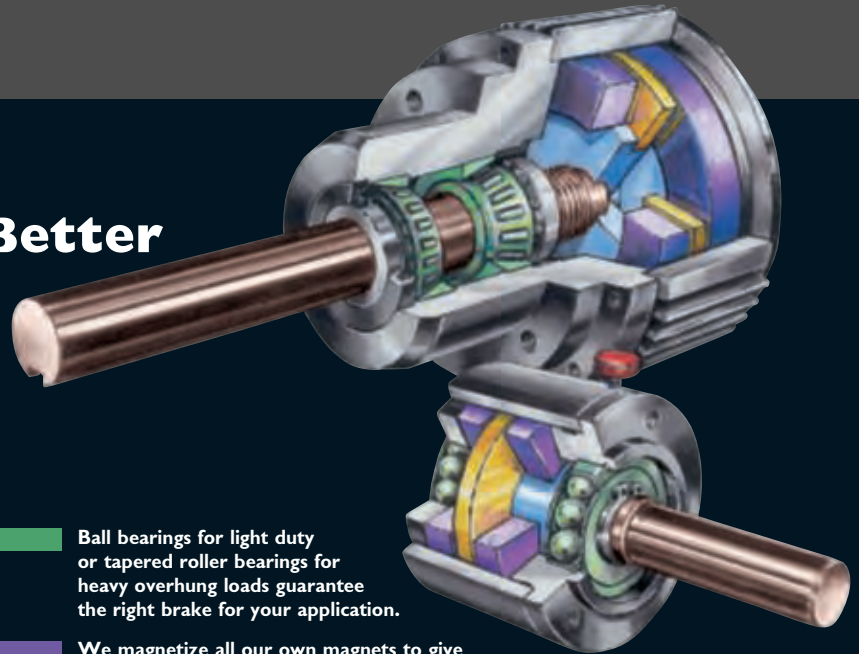

**Green** Ball bearings for light duty or tapered roller bearings for heavy overhung loads guarantee the right brake for your application.

**Purple** We magnetize all our own magnets to give you the right amount of poles, gauss and saturation for your application. This guarantees that brakes and clutches purchased from us years ago are the same as those purchased today.

**Blue** Special clamping arrangement allows easy disassembly and interchangeability should you decide to change a shaft, or to service our brakes at some time in the future.

**Yellow** The hysteresis disc is the heart of our design. The heat treating and grinding of this element assure years of trouble-free performance.

**Brown** Hundreds of shaft variations are available. Simply specify the shaft dimensions "A" and "B" for custom designs. On all of our ball bearing designs, the shafts can be easily interchanged and reversed in the field.

## How Mag Tech Brakes & Clutches Operate

All important internal clearances are ground to tolerances of less than .025mm (.001 inch). Magnet assemblies (purple) surround our hysteresis assembly (gold). When like poles face each other, they produce maximum magnetic saturation of the hysteresis disc, forcing lines of flux to travel circumferentially through the hysteresis disc. This produces maximum torque.

When opposite poles face each other they produce minimum saturation of the hysteresis disc. The lines of flux travel through the hysteresis disc. This produces minimum torque.

Combinations of adjustment angles between the two extremes give infinite adjustability. Because there are no contacting surfaces, the setting can be maintained indefinitely.

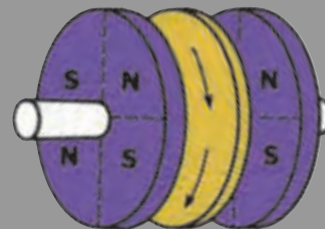

**Max Torque**



**Min Torque**



## Discover Magnetic Technologies

Since 1984 we have been designing and manufacturing high-quality permanent magnet hysteresis & eddy current brakes and clutches. We serve many industries including capping, wire & cable, fiber-optics, aerospace, converting, power transmission and medical. Magnetic brakes and clutches is our business.

We have the inventory, machinery and personnel to give you the very best magnetic brakes and clutches available. Whether you choose one of our standard models or require a custom design, our engineers understand tensioning, torque limiting and various applications that work best for magnetic brakes and clutches.

This catalog shows some of our more typical and popular units but only a fraction of our capabilities. Consult our website for more applications or call us with your request for a different shaft, coupling or a custom design. We know magnetic brakes and clutches.

## Popular Mounting Arrangements

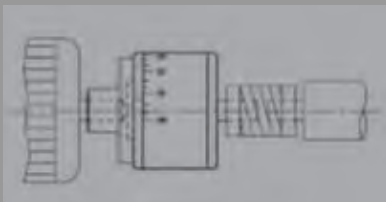

### As a Coupling

This is for load protection or torque limiting. The coupling style unit is directly connected to a motor and turns at the same speed as the motor until the torque is reached. At this point it will slip and still generate the max torque.

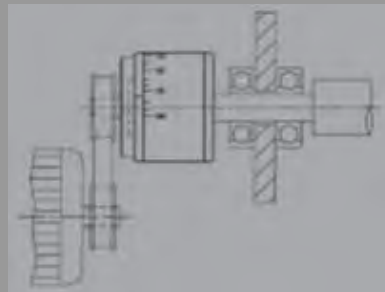

### As a Clutch

The unit is connected to a motor by a timing belt or gear. The housing is driven and the shaft is the output end.

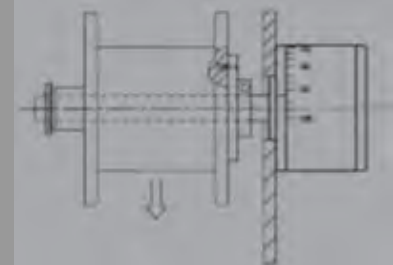

### As a Pay-Off Brake

Brake is stationary and the reel or material is fitted to the output shaft. The tension on the material will vary with the diameter.

# 513

## MODEL 513

Torque .001 to .014 Nm (.11 to 2 in. oz)

BENDING MOMENT .22 Nm (2 in lbs)

HEAT DISSIPATION 2.2 watts

## LOW TORQUE

Also available in:

-1 torque .001 to .007 Nm (.11 to 1 in. oz)

-2 torque .0003 to .002 Nm (.042 to .28 in. oz)

Specify -1 or -2 at end of the part number. Example: 513-001-1

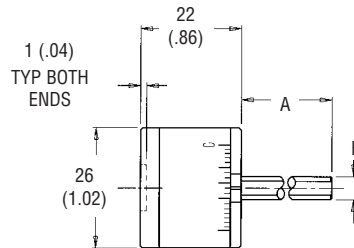

M3-0.5 TAP 4.5 (.18) DEEP  
3X EQ SP ON 15.5 (.610) B.C.  
BOTH ENDS

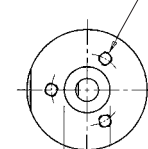

10 (.394)  
BOTH ENDS



### METRIC

MODEL	UNIT WEIGHT kg	INERTIA (kgm <sup>2</sup> )x10 <sup>-7</sup>	DIMENSIONS A B mm mm <sup>-03</sup>	
513-001	.071	2.5	13	5
513-007	.071	2.5	25	5
513-012	.071	2.5	13	4.75

### ENGLISH

MODEL	UNIT WEIGHT lb	INERTIA (in oz s <sup>2</sup> )x10 <sup>-5</sup>	DIMENSIONS A B in in <sup>-001</sup>	
513-001	.16	3.5	.51	.197
513-007	.16	3.5	.98	.197
513-012	.16	3.5	.51	.187

Other sizes available; specify both "A" and "B"

# 874

## MODEL 874

Torque .003 to .05 Nm (.03 to .44 in.lbs)

BENDING MOMENT .5Nm (4 in lbs)

HEAT DISSIPATION 5.5 watts

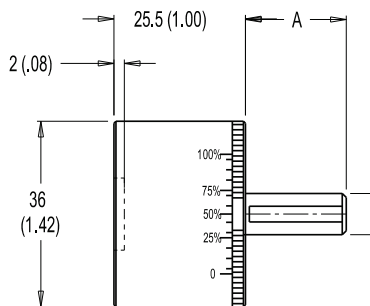

M3-0.5 TAP 5.5 (.22) DEEP  
3X EQ SP ON 24.0 (.945) B.C.  
BOTH ENDS

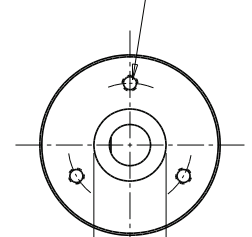

14 (.551)  
BOTH ENDS



### METRIC

MODEL	UNIT WEIGHT kg	INERTIA (kgm <sup>2</sup> )x10 <sup>-6</sup>	DIMENSIONS A B mm mm <sup>-03</sup>	
874-001	.16	1.7	19.5	8

### ENGLISH

MODEL	UNIT WEIGHT lb	INERTIA (in oz s <sup>2</sup> )x10 <sup>-4</sup>	DIMENSIONS A B in in <sup>-001</sup>	
874-001	.35	2.4	.77	.315

Other sizes available; specify both "A" and "B"

**MODEL 520**

Torque .003 to .14 Nm (.03 to 1.25 in.lbs)  
 BENDING MOMENT 1Nm (9 in lbs)  
 HEAT DISSIPATION 13 watts

**LOW TORQUE**

Also available in:  
 -I torque .001 to .08 Nm (.013 to .75 in. lbs)  
 Specify -I at end of the part number. Example: 520-001-I

**520**

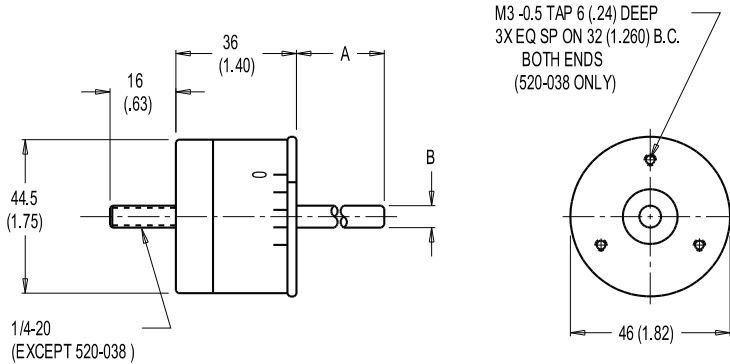

METRIC			DIMENSIONS		ENGLISH			DIMENSIONS	
MODEL	UNIT WEIGHT	INERTIA	A	B	MODEL	UNIT WEIGHT	INERTIA	A	B
	kg	(kgm <sup>2</sup> )x10 <sup>-5</sup>	mm	mm <sup>-03</sup>		lb	(in oz s <sup>2</sup> )x10 <sup>-3</sup>	in	in <sup>-001</sup>
520-012	.30	.45	25.4	4.75	520-012	.67	.64	1.0	.187
520-004	.32	.45	25.4	6.35	520-004	.71	.64	1.0	.25
520-006	.33	.45	50.8	6.35	520-006	.73	.64	2.0	.25
520-038	.31	.45	25.4	6.00	520-038	.69	.64	1.0	.236

Other sizes available; specify both "A" and "B"



**MODEL 527**

Torque .003 to .14 Nm (.03 to 1.25 in.lbs)  
 BENDING MOMENT 4 Nm (35 in lbs)  
 HEAT DISSIPATION 13 Watts

**LOW TORQUE**

Also available in:  
 -I torque .001 to .08 Nm (.013 to .75 in. lbs)  
 Specify -I at end of the part number. Example: 527-001-I

**527**

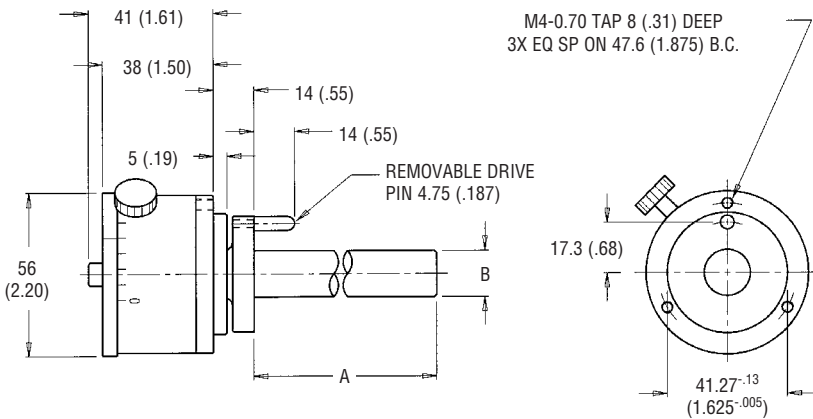

METRIC			DIMENSIONS		ENGLISH			DIMENSIONS	
MODEL	UNIT WEIGHT	INERTIA	A	B	MODEL	UNIT WEIGHT	INERTIA	A	B
	kg	(kgm <sup>2</sup> )x10 <sup>-5</sup>	mm	mm <sup>-03</sup>		lb	(in oz s <sup>2</sup> )x10 <sup>-3</sup>	in	in <sup>-001</sup>
527-0141	.77	2.1	158.0	15.00	527-0141	1.7	3.0	6.2	.590
527-016	.73	2.1	127.0	15.87	527-016	1.6	3.0	5.0	.625
527-029	.95	2.9	279.4	15.87	527-029	2.1	4.1	11.0	.625
527-077	.91	5.1	203.2	22.00	527-077	2.5	7.3	8.0	.866
527-035	.91	3.4	181.6	25.40	527-035	2.0	4.8	7.1	1.00

Other sizes available; specify both "A" and "B"



# 655

## MODEL 655

Torque .014 to .56 Nm (.12 to 5.0 in lbs)

BENDING MOMENT 5 Nm (40 in lbs)  
HEAT DISSIPATION 18 Watts

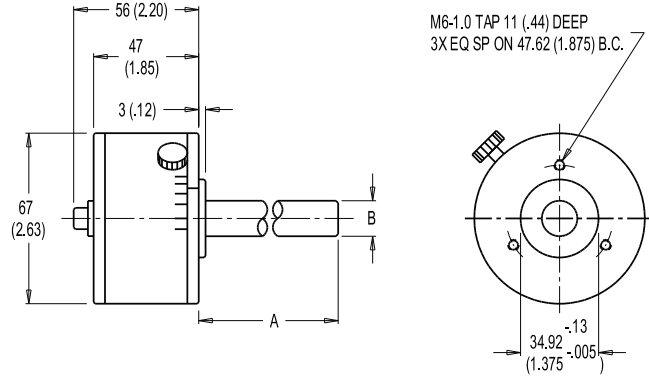

METRIC

UNIT  
MODEL WEIGHT INERTIA  
kg (kgm<sup>2</sup>)x10<sup>-5</sup>

ENGLISH

UNIT  
MODEL WEIGHT INERTIA  
lb (in oz s<sup>2</sup>)x10<sup>-3</sup>

MODEL	WEIGHT	INERTIA	DIMENSIONS		MODEL	WEIGHT	INERTIA	DIMENSIONS	
			A	B				A	B
			mm	mm <sup>-03</sup>				in	in <sup>-001</sup>
655-065	1.45	2.8	178.0	15.00	655-065	3.2	4.0	7.0	.590
655-001	1.45	3.0	178.0	15.87	655-001	3.2	4.1	7.0	.625
655-002	1.59	4.0	178.0	19.05	655-002	3.5	5.6	7.0	.750
655-066	1.73	4.8	178.0	22.00	655-066	3.8	6.7	7.0	.866
655-043	1.90	9.0	266.7	25.40	655-043	4.2	12.7	10.5	1.00

Other sizes available; specify both "A" and "B"



# MB6HD

HEAVY DUTY

## MODEL MB6HD HEAVY DUTY

Torque .035 to .62 Nm (.31 to 5.5 in lbs)

BENDING MOMENT 12 Nm (100 in lbs)  
HEAT DISSIPATION 18 Watts

Tapered Roller Bearings for Overhung Load. See Inside Front Cover.

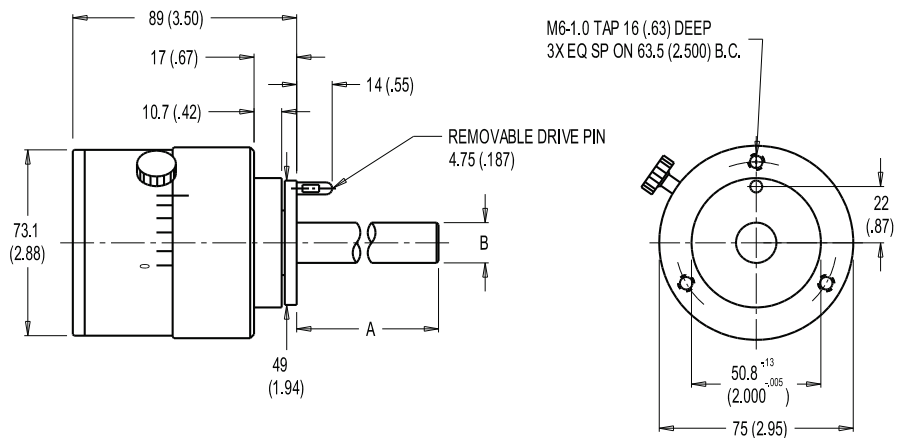

METRIC

UNIT  
MODEL WEIGHT INERTIA  
kg x10<sup>-5</sup>

ENGLISH

UNIT  
MODEL WEIGHT INERTIA  
lb x10<sup>-3</sup>

MODEL	WT	INERTIA	DIMENSIONS		MODEL	WT	INERTIA	DIMENSIONS	
			A	B				A	B
			mm	mm <sup>-03</sup>				in	in <sup>-001</sup>
MB6HD-040	2.40	6.9	241.3	15.00	MB6HD-040	5.3	9.8	9.5	.590
MB6HD-001	2.31	6.7	152.4	15.87	MB6HD-001	5.1	9.5	6.0	.625
MB6HD-002	2.45	7.1	241.3	15.87	MB6HD-002	5.4	10.1	9.5	.625
MB6HD-029	2.90	10.9	270.0	22.00	MB6HD-029	6.4	15.4	10.6	.866
MB6HD-031	3.30	15.8	304.8	25.40	MB6HD-031	7.3	22.5	12.0	1.00

Other sizes available; specify both "A" and "B"



## MODEL 523

Torque .03 to 1.36 Nm (.3 to 12 in lbs)

BENDING MOMENT 9 Nm (80 in lbs)

HEAT DISSIPATION 28 Watts

# 523

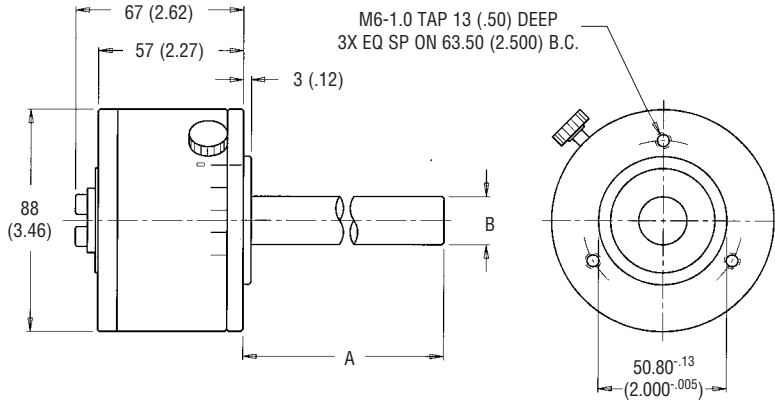

METRIC			ENGLISH						
MODEL	UNIT WEIGHT	INERTIA	DIMENSIONS A	DIMENSIONS B	MODEL	UNIT WEIGHT	INERTIA	DIMENSIONS A	DIMENSIONS B
	kg	(kgm <sup>2</sup> )x10 <sup>-5</sup>	mm	mm <sup>-03</sup>		lb	(in oz s <sup>2</sup> )x10 <sup>-3</sup>	in	in <sup>-001</sup>
523-0192	2.08	10.0	203.2	15.00	523-0192	4.6	14.1	8.0	.590
523-003	1.91	9.5	54.0	15.87	523-003	4.2	13.4	2.1	.625
523-016	2.27	10.6	279.4	15.87	523-016	5.0	15.0	11.0	.625
523-002	1.95	9.5	54.0	19.05	523-002	4.3	13.4	2.1	.750
523-006	2.45	12.0	279.4	19.05	523-006	5.4	17.0	11.0	.750

Other sizes available; specify both "A" and "B"



## MODEL 523 COUPLING STYLE

Torque .03 to 1.36 Nm (.3 to 12 in lbs)

BENDING MOMENT 9 Nm (80 in lbs)

HEAT DISSIPATION 28 Watts

# 523

COUPLING STYLE

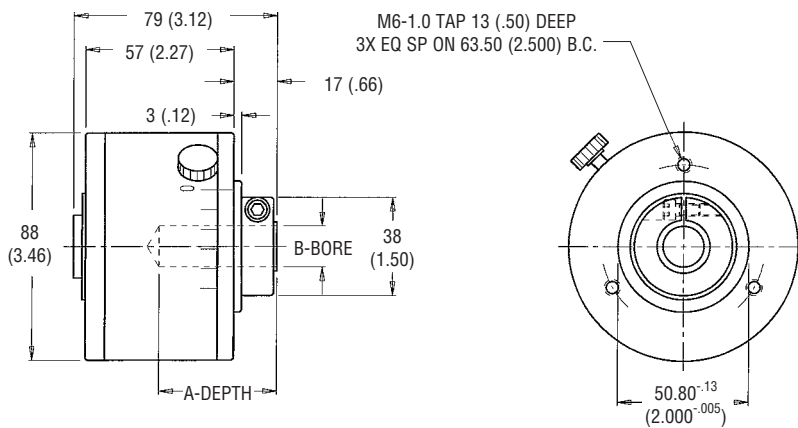

METRIC			ENGLISH						
MODEL	UNIT WEIGHT	INERTIA	DIMENSIONS A	DIMENSIONS B	MODEL	UNIT WEIGHT	INERTIA	DIMENSIONS A	DIMENSIONS B
	kg	(kgm <sup>2</sup> )x10 <sup>-5</sup>	mm	mm <sup>-03</sup>		lb	(in oz s <sup>2</sup> )x10 <sup>-3</sup>	in	in <sup>-001</sup>
523-095	1.86	7.8	44.5	12.70	523-095	4.1	11.0	1.75	.500
523-0193	1.86	7.8	44.5	15.00	523-0193	4.1	11.0	1.75	.590
523-096	1.86	7.8	44.5	15.87	523-096	4.1	11.0	1.75	.625

Other sizes available; specify both "A" and "B"



# MB13HD

## HEAVY DUTY

### MODEL MB13HD HEAVY DUTY

Torque .15 to 1.46 Nm (1.3 to 13 in lbs)

BENDING MOMENT 225 Nm (2000 in lbs)

HEAT DISSIPATION 28 Watts

Tapered Roller Bearings for Overhung Load. See Inside Front Cover.

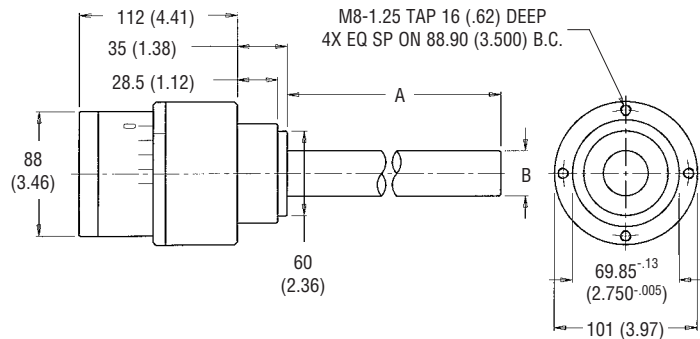

#### METRIC

MODEL	UNIT WEIGHT kg	INERTIA (kgm <sup>2</sup> )x10 <sup>-5</sup>	DIMENSIONS A B mm mm <sup>-03</sup>	
MB13HD-004	7.8	64	458	31.75
MB13HD-006	8.6	64	458	38.1

#### ENGLISH

MODEL	UNIT WEIGHT lb (in oz s <sup>2</sup> )x10 <sup>-3</sup>	INERTIA	DIMENSIONS A B in in <sup>-001</sup>	
MB13HD-004	17.7	90	18.0	1.250
MB13HD-006	19.0	90	18.0	1.500

Other sizes available; specify both "A" and "B"

# 535

### MODEL 535

Torque .11 to 2.8 Nm (1 to 25 in lbs)

BENDING MOMENT 13.5 Nm (120 in lbs)

HEAT DISSIPATION 72 Watts

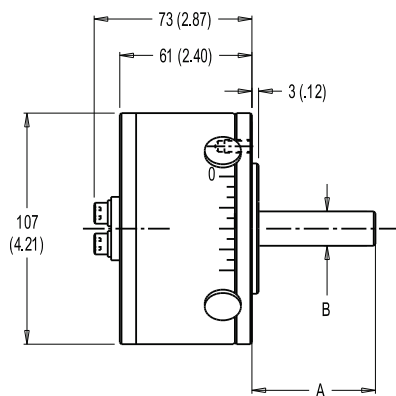

M6-1.00 TAP 12 (.47) DEEP  
3X EQ SP ON 76.20 (3.000) B.C.

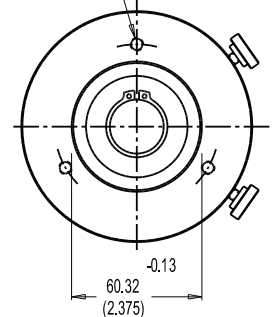

#### METRIC

MODEL	UNIT WEIGHT kg	INERTIA (kgm <sup>2</sup> )x10 <sup>-6</sup>	DIMENSIONS A B mm mm <sup>-03</sup>	
535-001	3.15	0.939	57.0	15.88
535-003	3.50	0.981	279.4	15.88
535-005	3.79	1.1	242.0	22.00

#### ENGLISH

MODEL	UNIT WEIGHT lb (in oz s <sup>2</sup> )x10 <sup>-4</sup>	INERTIA	DIMENSIONS A B in in <sup>-001</sup>	
535-001	6.97	1.33	2.12	.625
535-003	7.73	1.39	11.00	.625
535-005	8.36	1.55	9.53	.866

Other sizes available; specify both "A" and "B"





## MODEL 610

Torque .14 to 4.5 Nm (1.2 to 40 in lbs)

BENDING MOMENT 17 Nm (150 in lbs)

HEAT DISSIPATION 95 Watts

# 610

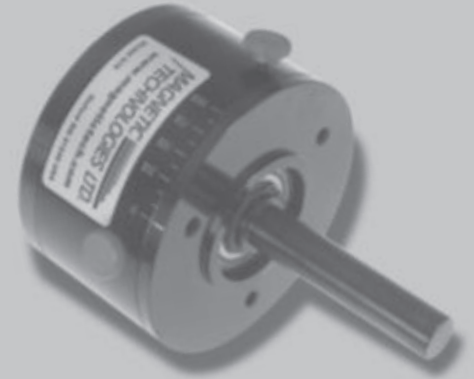
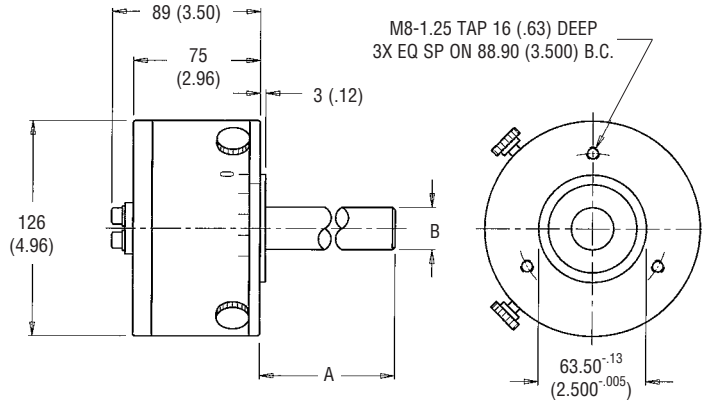

METRIC			DIMENSIONS		ENGLISH			DIMENSIONS	
MODEL	UNIT WEIGHT	INERTIA	A	B	MODEL	UNIT WEIGHT	INERTIA	A	B
	kg	(kgm <sup>2</sup> )x10 <sup>-5</sup>	mm	mm <sup>-03</sup>		lb	(in oz s <sup>2</sup> )x10 <sup>-3</sup>	in	in <sup>-001</sup>
610-014	4.60	39.0	88.9	19.05	610-014	10.2	55.0	3.5	.750
610-095	5.12	40.0	242.0	22.00	610-095	11.3	57.0	9.5	.866
610-011	5.00	40.0	152.4	25.00	610-011	11.0	57.0	6.0	.984
610-024	5.40	44.0	254.0	25.00	610-024	11.9	62.0	10.0	.984
610-055	5.62	46.0	304.8	25.40	610-055	12.4	65.0	12.0	1.000

Other sizes available; specify both "A" and "B"



## MODEL 610 COUPLING STYLE

Torque .14 to 4.5 Nm (1.2 to 40 in lbs)

BENDING MOMENT 17 Nm (150 in lbs)

HEAT DISSIPATION 95 Watts

# 610

COUPLING STYLE

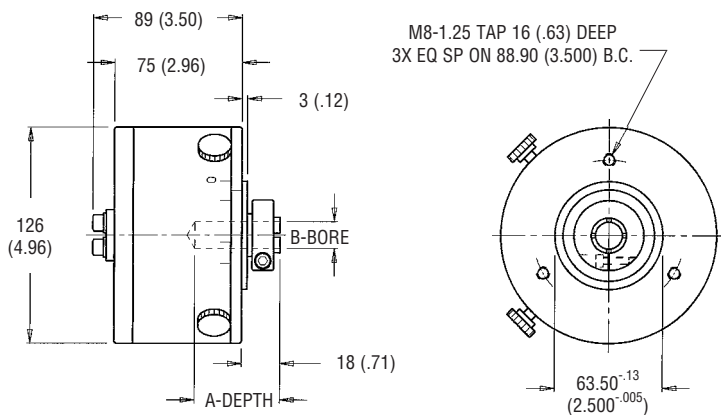

METRIC			DIMENSIONS		ENGLISH			DIMENSIONS	
MODEL	UNIT WEIGHT	INERTIA	A	B	MODEL	UNIT WEIGHT	INERTIA	A	B
	kg	(kgm <sup>2</sup> )x10 <sup>-5</sup>	mm	mm <sup>+0.03</sup>		lb	(in oz s <sup>2</sup> )x10 <sup>-3</sup>	in	in <sup>+001</sup>
610-029	4.80	37.0	76.2	15.87	610-029	10.6	52.0	3.00	.625
610-048	4.80	37.0	63.5	16.00	610-048	10.6	52.0	2.50	.630
610-035	4.80	37.0	63.5	19.05	610-035	10.6	52.0	2.50	.750

Other sizes available; specify both "A" and "B"



# MB70HD

HEAVY DUTY

## MODEL MB70HD HEAVY DUTY

Torque .42 to 7.9 Nm (4 to 70 in lbs)

BENDING MOMENT 225 Nm (2000 in lbs)  
HEAT DISSIPATION 150 Watts

Tapered Roller Bearings for Overhung Load. See Inside Front Cover.

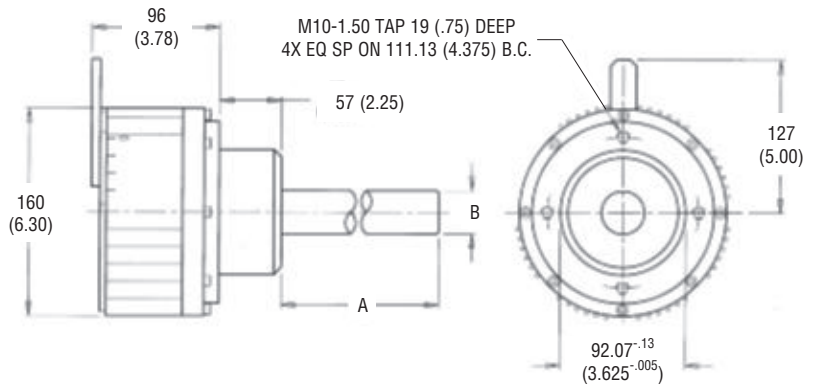

METRIC

MODEL	UNIT WEIGHT kg	INERTIA (kgm <sup>2</sup> ) x10 <sup>-5</sup>	DIMENSIONS A B mm mm <sup>-03</sup>	
MB70HD-008	11.32	177.0	88.9	25.40
MB70HD-026	9.51	188.0	355.6	25.40
MB70HD-029	10.70	177.0	340.0	35.00
MB70HD-005	9.48	200.0	152.4	38.10
MB70HD-004	13.60	226.0	304.8	38.10

ENGLISH

MODEL	UNIT WEIGHT lb	INERTIA (in oz s <sup>2</sup> ) x10 <sup>-3</sup>	DIMENSIONS A B in in <sup>-001</sup>	
MB70HD-008	25.0	250.0	3.5	1.000
MB70HD-026	21.0	265.0	14.0	1.000
MB70HD-029	23.6	250.0	13.4	1.378
MB70HD-005	20.9	285.0	6.0	1.500
MB70HD-004	30.0	320.0	12.0	1.500

Other sizes available; specify both "A" and "B"

# 806

HOLLOW BORE

## MODEL 806

Torque .33 to 7.9 Nm (3 to 70 in lbs)

BENDING MOMENT 23 Nm (200 in lbs)  
HEAT DISSIPATION 150 Watts



Ø 10.3 (.40) x 8 (.31) DEEP  
4X EQ SP ON 101 (4.00) B.C.  
BOTH SIDES  
(FOR SPANNER WRENCH)

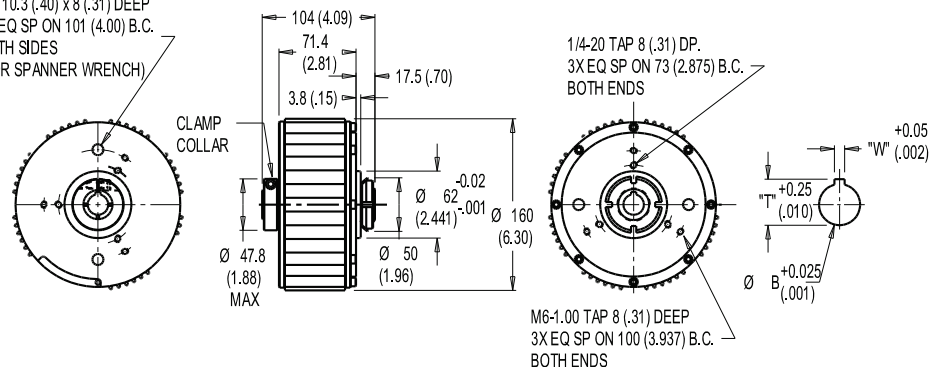

METRIC

MODEL	UNIT WT kg	INERTIA (kgm <sup>2</sup> ) x10 <sup>-5</sup>	DIMENSIONS B W T mm mm mm		
806-016	6.45	138	15.88	4.75	18.00
806-017	6.45	138	16.00	5.00	18.30
806-018	6.45	138	19.00	6.00	21.80
806-019	6.45	138	19.05	4.75	21.26
806-020	6.45	138	22.23	N/A	N/A

ENGLISH

MODEL	UNIT WT lb	INERTIA (in oz s <sup>2</sup> ) x10 <sup>-3</sup>	DIMENSIONS B W T in in in		
806-016	14.2	196	.625	.187	.709
806-017	14.2	196	.630	.197	.721
806-018	14.2	196	.760	.24	.872
806-019	14.2	196	.750	.187	.837
806-020	14.2	196	.875	N/A	N/A

Other sizes available; specify both "A" and "B"

## MODEL 663

Torque .33 to 7.9 Nm (3 to 70 in lbs)

BENDING MOMENT 23 Nm (200 in lbs)  
HEAT DISSIPATION 150 Watts

# 663

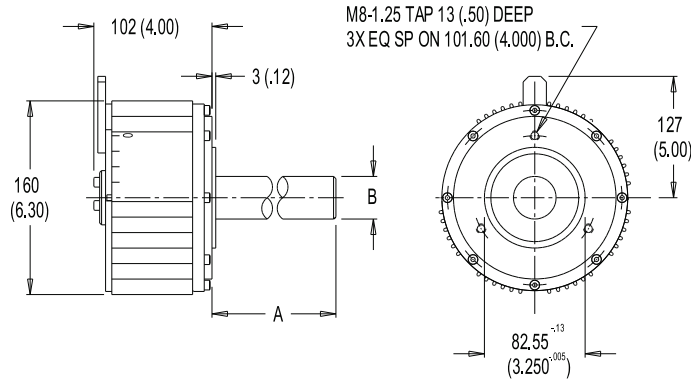

METRIC				ENGLISH					
MODEL	UNIT WEIGHT	INERTIA	DIMENSIONS		MODEL	UNIT WEIGHT	INERTIA	DIMENSIONS	
	kg	(kgm <sup>2</sup> )x10 <sup>-5</sup>	A	B		lb	(in oz s <sup>2</sup> )x10 <sup>-3</sup>	A	B
			mm	mm <sup>-03</sup>				in	in <sup>-001</sup>
663-041	8.92	141.0	282.0	22.00	663-041	19.7	200.0	11.1	.866
663-042	8.43	141.0	88.9	25.00	663-042	18.6	200.0	3.5	.984
663-001	8.43	141.0	88.9	25.40	663-001	18.6	200.0	3.5	1.000
663-003	9.10	141.0	254.0	25.40	663-003	20.0	200.0	10.0	1.000

Other sizes available; specify both "A" and "B"



## MODEL MB140

Torque .68 to 15 Nm (6 to 140 in lbs)

BENDING MOMENT 23 Nm (200 in lbs)  
HEAT DISSIPATION 180 Watts

## MODEL MB320

Torque 2 to 36 Nm (18 to 320 in lbs)

BENDING MOMENT 40 Nm (350 in lbs)  
HEAT DISSIPATION 350 Watts

# MB140 MB320

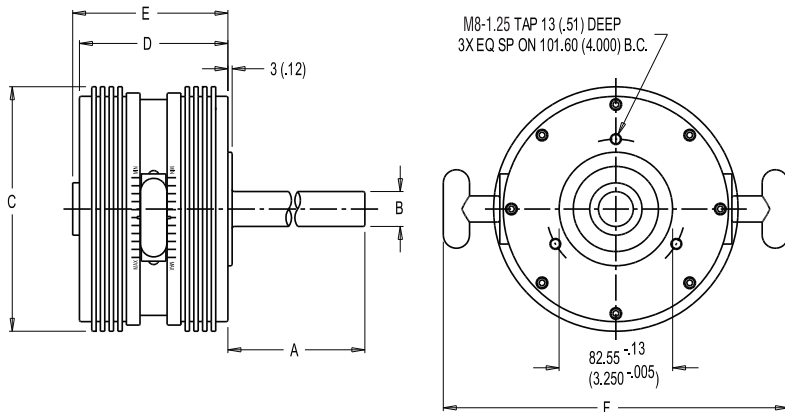

METRIC									
MODEL	UNIT WT	INERTIA	A	B	DIMENSIONS				F
	kg	(kgm <sup>2</sup> )x10 <sup>-5</sup>	mm	mm <sup>-03</sup>	C	D	E	F	mm
MB140-001	11.8	282	76	25.40	178	112	117	246	
MB320-001	22.7	1117	94.7	25.40	215	137.2	147.3	284.5	

ENGLISH									
MODEL	UNIT WT	INERTIA	A	B	C	D	E	F	
	lb	(oz-in-s <sup>2</sup> )x10 <sup>-5</sup>	in	in <sup>-001</sup>	in	in	in	in	in
MB140-001	26	400	3.00	1.000	7.00	4.41	4.61	9.65	
MB320-001	50	1577	3.73	1.000	8.46	5.40	5.8	11.2	

Other sizes available; specify both "A" and "B"



# 651

## CONSTANT TENSION

Shown is 651-006R  
(right hand configuration)



## MODEL 651

Designed to provide constant surface tension.  
This brake has a urethane housing that rides on the material diameter insuring constant tension.

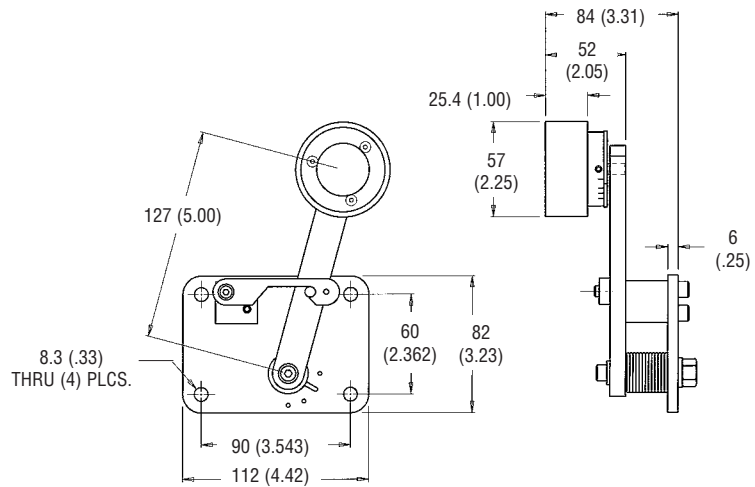

MODEL	TENSION RANGE	UNIT WEIGHT	HEAT DISSIPATION
651-006L	.014 to .50 kg (.03 to 1.11 lbs.)	1.2 kg (2.6 lbs.)	13 watts

Call or see our website for more information.

# 600

## CONSTANT TENSION

Shown is 600-040L  
(left hand configuration)



## MODEL 600

Designed to provide constant surface tension.  
This brake has a urethane housing that rides on the material diameter insuring constant tension.

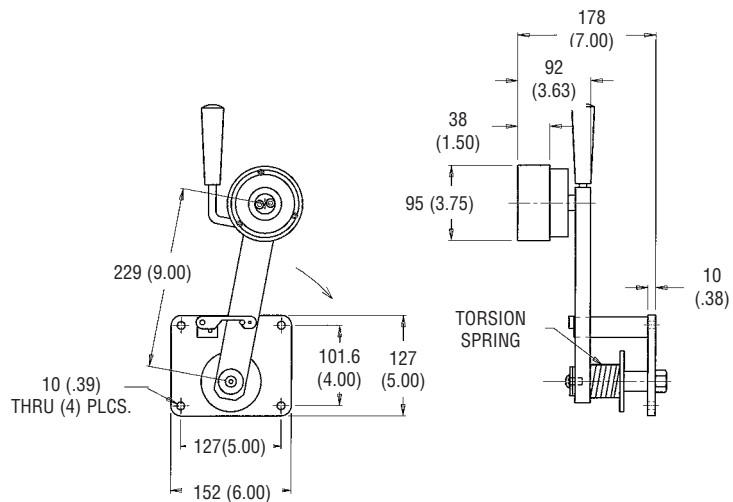

MODEL	TENSION RANGE	UNIT WEIGHT	HEAT DISSIPATION
600-040L	.23 to 3 kg (.5 to 6.4 lbs.)	4.6 kg (10.7 lbs.)	28 watts

Call or see our website for more information.

CONSTANT TENSION BRAKE WITH FOLLOWER ARM

# CT12

Torque 0.03 to 1.36 Nm (3 to 12 in lbs)  
HEAT DISSIPATION 28 Watts

# CT36

Torque 0.14 to 4.0 Nm (1.2 to 36 in lbs)  
HEAT DISSIPATION 95 Watts

# CT70

Torque 0.34 to 7.9 Nm (3 to 70 in lbs)  
HEAT DISSIPATION 150 Watts

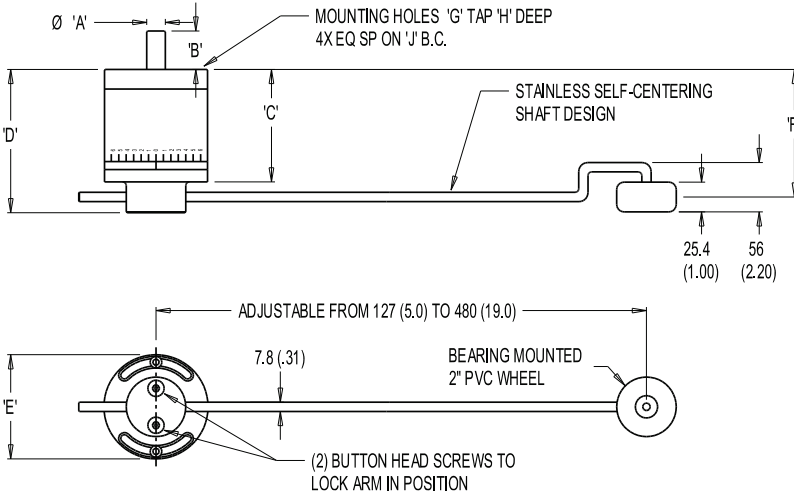

## MODEL CT12

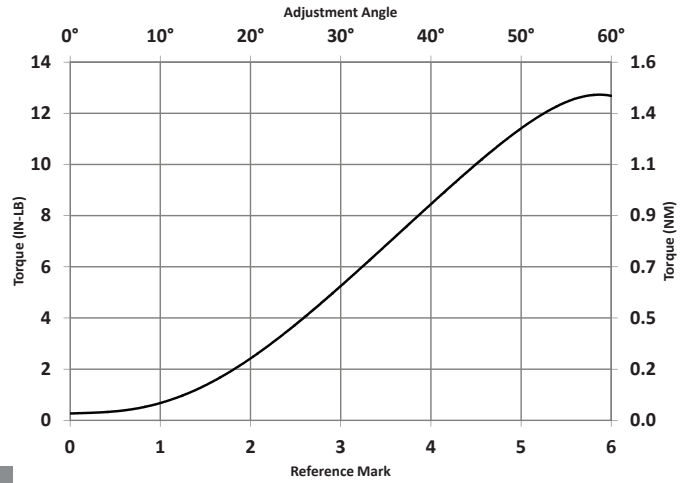

METRIC

MODEL	A	B	C	D	E	F	G	H	J	WT
	mm	mm	mm	mm	mm	mm	mm	mm	mm	KG
CT12-001	15.88	53.8	96.0	113.8	87.9	106.7	M6	12.7	76.2	3.5
CT36-001	19.05	90.2	94.7	125.0	119.4	114.6	M8	10.7	88.9	7.3
CT70-001	25.40	88.9	119.4	150.1	152.4	139.7	M8	15.7	101.6	10.5

ENGLISH

MODEL	A	B	C	D	E	F	G	H	J	WT
	in	in	in	in	in	in	in	in	in	LB
CT12-001	0.625	2.12	3.78	4.48	3.46	4.20	M6	0.50	3.00	7.7
CT36-001	0.750	3.55	3.73	4.92	4.70	4.51	M8	0.42	3.50	16
CT70-001	1.000	3.50	4.70	5.91	6.00	5.50	M8	0.62	4.00	23

## MODEL CT36

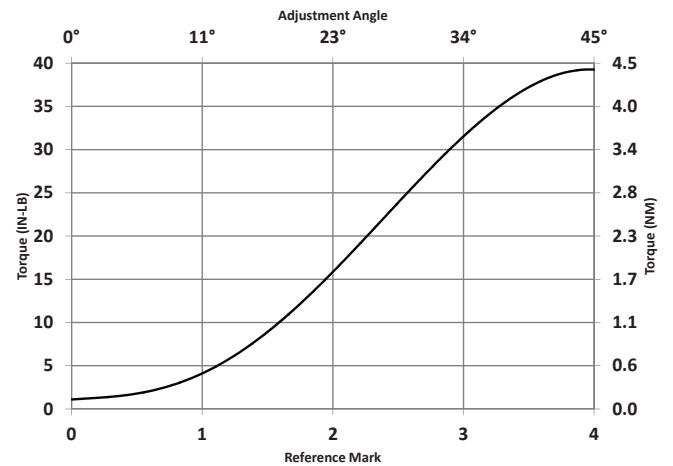

## MODEL CT70

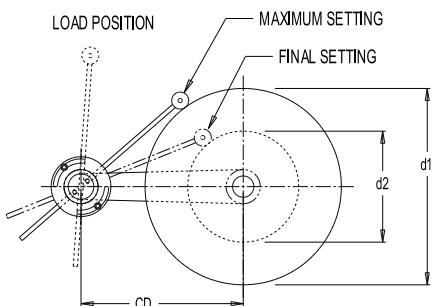
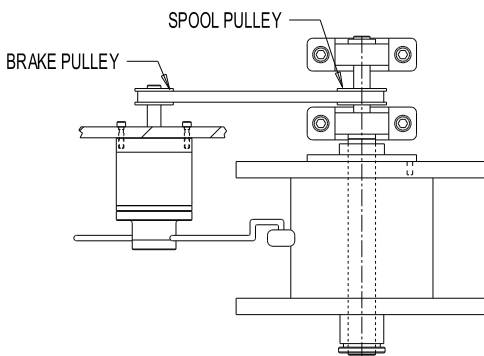
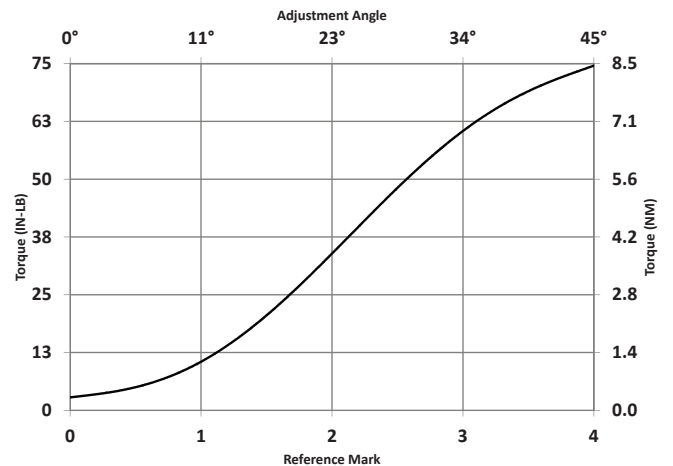

The follower arm rides on diameter "d<sub>1</sub>" following material down to diameter "d<sub>2</sub>". "Arm angle" change decreases the brake torque to maintain constant tension from "d<sub>1</sub>" to "d<sub>2</sub>". Recommended for dedicated applications.

# 822

**CUSTOM PAYOFF STANDS**

## MULTI POSITION VERTICAL STAND

Tubular steel construction. Posts rotate, fits various Mag Tech brakes, small footprint. Visit our website or call the factory for more information.

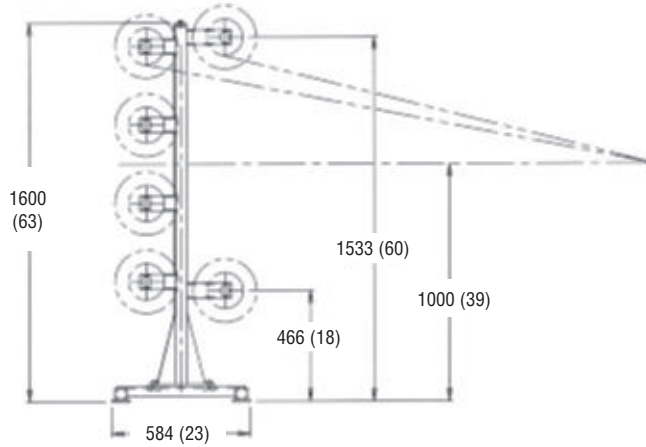

# 600

**CUSTOM PAYOFF STANDS**

## CONSTANT TENSION STAND

Portable stand using our 600 type brakes for surface tensioning. Available in several sizes. Visit our website or call the factory for more information.

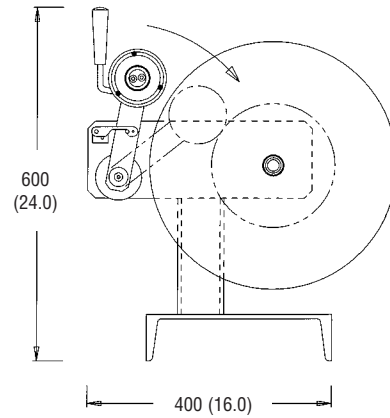

# 673

**CUSTOM PAYOFF STANDS**

## MULTI POSITION HORIZONTAL STAND

Movable with casters. Fits 527, 609, 523, and many other models. Visit our website or call the factory for more information.

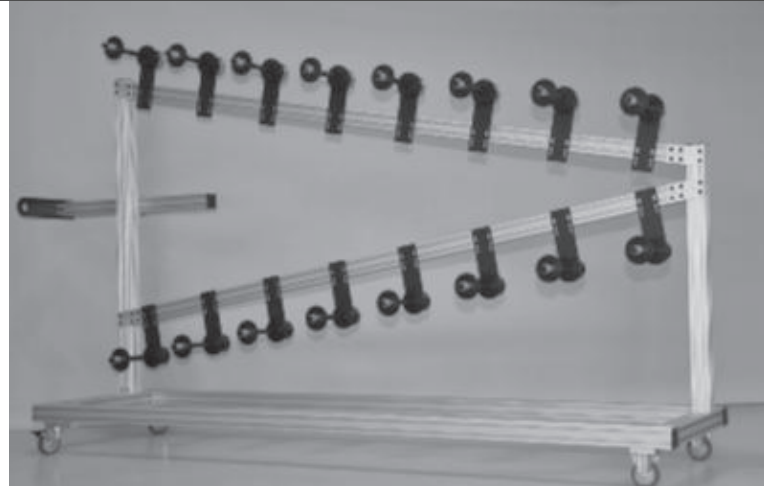
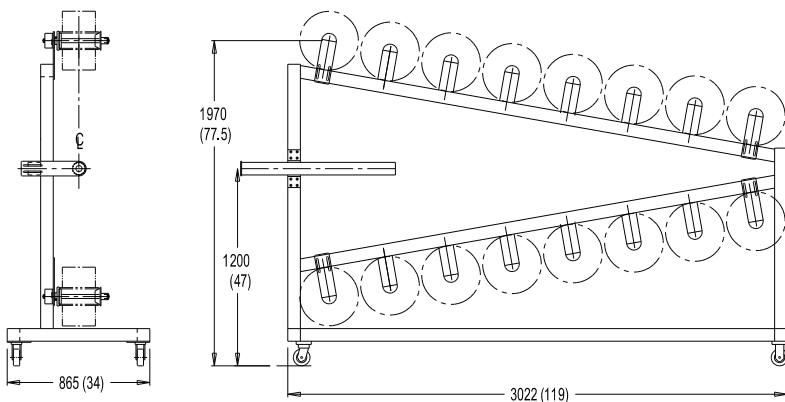

# FastLock

Fast locking collars.  
One hand operation, no tools required.  
Usable on non-hardened shafts.  
Shaft tolerance  $+0.02$  to  $-0.38\text{mm}$  ( $+0.001$  to  $-0.015$  in.)

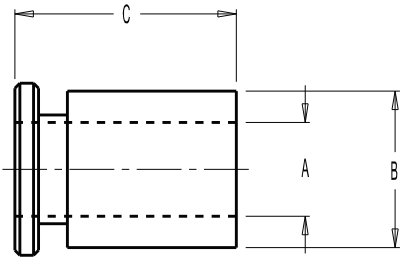

## AVAILABLE FASTLOCK MODELS

METRIC	MM	MM	MM	WT
MODEL	A	B	C	Kg
FL-6mm	6	18.5	26	0.03
FL-8mm	8	18.5	26	0.03
FL-10mm	10	22	45	0.08
FL-15mm	15	28	45	0.13
FL-16mm	16	28	45	0.13
FL-18mm	18	31	45	0.14
FL-20mm	20	37	45	0.21
FL-22mm	22	37	45	0.22
FL-25mm	25	37	45	0.19
FL-30mm	30	50	45	0.39
FL-32mm	32	57	48	0.53
FL-35mm	35	57	48	0.47
FL-36mm	36	57	48	0.45
FL-40mm	40	60	48	0.56
FL-45mm	45	69	48	0.84
FL-50mm	50	69	48	0.70
FL-55mm	55	75	49	0.62
FL-56mm	56	75	49	0.60

ENGLISH	IN	IN	IN	WT
MODEL	A	B	C	Lb
FL-.250	0.250	0.73	1.00	0.07
FL-.3125	0.3125	0.73	1.00	0.07
FL-.375	0.375	0.85	1.78	0.19
FL-.437	0.437	0.85	1.78	0.18
FL-.500	0.500	1.10	1.78	0.29
FL-.562	0.562	1.10	1.78	0.26
FL-.625	0.625	1.10	1.78	0.25
FL-.750	0.750	1.23	1.78	0.31
FL-.875	0.875	1.45	1.78	0.37
FL-1.00	1.000	1.45	1.78	0.32
FL-1.25	1.250	2.23	1.87	1.13
FL-1.375	1.375	2.23	1.87	1.00
FL-1.50	1.500	2.23	1.87	0.93
FL-1.625	1.625	2.35	1.87	0.91
FL-1.75	1.750	2.72	1.87	0.91
FL-1.875	1.875	2.72	1.87	0.82
FL-2.0	2.000	2.95	1.87	1.54
FL-2.50	2.500	3.47	1.87	1.87
FL-3.0	3.000	3.47	1.87	1.30

Other sizes available

**FAST ON**

**FAST OFF**

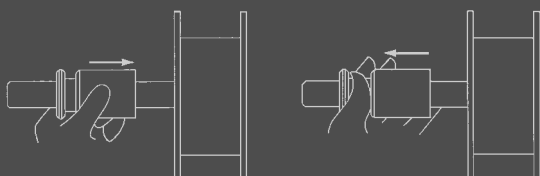

# Accessories

## ADAPTORS

Utilized for clutch or clutch coupling arrangements. Comes with mounting hardware. See page 1.

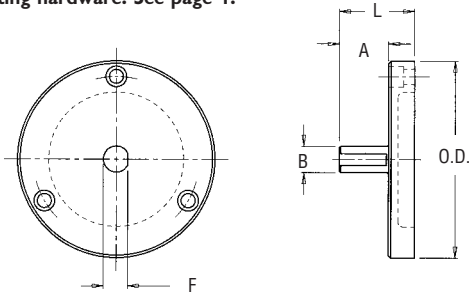

MODEL	FITS BRAKE	OD		A		L		B		F
		mm	in	mm	in	mm	in	mm	in	mm in
750-075	655	63.5	2.50	25.4	1.00	33.2	1.31	9.5	.375	Flat
750-005	523	82.5	3.25	25.4	1.00	33.2	1.31	9.5	.375	Flat
750-076	610	114	4.50	30.5	1.20	44.5	1.75	12.7	.500	1/8 <sup>th</sup> Key
750-077	663	127	5.00	34.3	1.35	47	1.85	19.0	.750	3/16 <sup>th</sup> Key

Other sizes available

## 710 DRIVE PLATE

### MODEL 710-040

Light weight, low inertia for fiber optics.

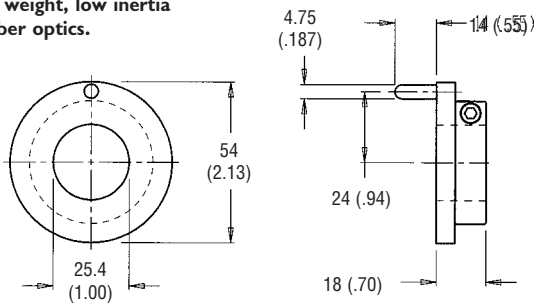

## SPOOL ADAPTORS

### MODEL 750-184

To mount 1 1/4" reels on 1" shafts.

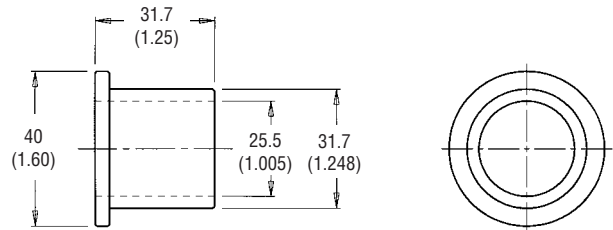

Other sizes available

## CONES & SPIKED DRIVE PLATES

For Armid yarns. See photo back page.

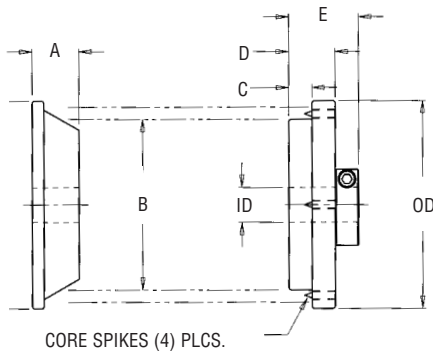

MODEL	ID		A		B		C		D		E		OD	
	mm	in	mm	in	mm	in	mm	in	mm	in	mm	in	mm	in
750-034	19.1	.750	25.4	1.00	93.5	3.68	13	.51	25.4	1.00	38	1.5	113	4.47
750-072	25.5	1.00	25.4	1.00	93.5	3.68	13	.51	25.4	1.00	38	1.5	113	4.47

Other sizes available

## TAPE PLUGS

### MODEL 750-052

Grips standard 3" (76mm) cores

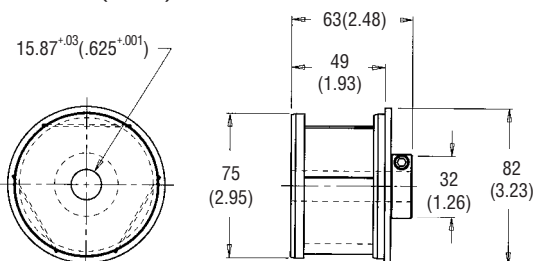

### MODEL 750-028

Grips standard 3" (76mm) cores

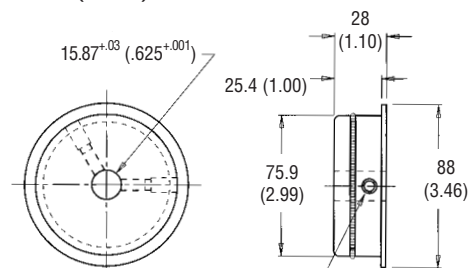

(2) 1/4-28 SET SCREWS 120° APART



## MOUNTING BRACKETS

See photo back cover, comes with mounting hardware.

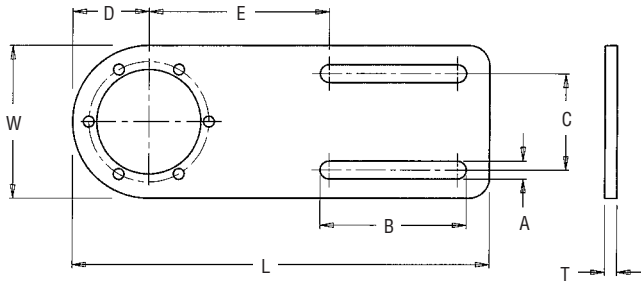

MODEL	FITS BRAKE	L		W		T	A		B		C		D		E		
		mm	in	mm	in		mm	in	mm	in	mm	in	mm	in	mm	in	
700-014M	513	127	5.00	25.4	1.00	3	.12	6.6	.26	45	1.7	NA	NA	12.7	.50	58	2.3
700-001M	527	163	6.4	58	2.3	5	.19	7	.28	51	2.0	38	1.50	28	1.12	71	2.8
700-006M	655	254	10.0	71	2.8	6	.25	9	.34	76	3.0	44	1.75	35	1.37	127	5.0
700-019M	880	356	14.0	102	.31	8	.41	10.5	.41	102	4.0	76	3.00	51	2.00	178	7.0
700-022M	535	292	11.5	102	4.0	6	.25	11	.44	89	3.5	70	2.75	51	2.00	133	5.25
700-002M	523 & 609	305	12.0	89	3.5	6	.25	11	.44	79	3.1	64	2.50	44	1.75	157	6.2
700-003M	610	305	12.0	127	5.0	6	.25	11	.44	89	3.5	89	3.50	64	2.50	130	5.1
700-007M	663	406	16.0	152	6.0	8	.31	14	.56	127	5.0	102	4.00	83	3.26	180	7.1

## 705 DRIVE PLATE

Multi-position pin with non marring clamp collar design.

Part #	D		A		T	
	mm	in	mm	in	mm	in
705-0433	11.00	0.433	27.9	1.10	17.3	0.68
705-0500	12.70	0.500	28.4	1.12	16.8	0.66
705-0591	15.00	0.591	34.0	1.34	19.3	0.76
705-0625	15.88	0.625	33.3	1.31	17.5	0.69
705-0630	16.00	0.630	34.0	1.34	19.3	0.76
705-0750	19.05	0.750	38.1	1.50	19.1	0.75
705-0787	20.00	0.787	40.0	1.57	21.3	0.84
705-0866	22.00	0.866	42.0	1.65	21.3	0.84
705-0875	22.23	0.875	41.1	1.62	19.1	0.75
705-0984	25.00	0.984	45.0	1.77	21.3	0.84
705-0100	25.40	1.000	44.5	1.75	19.1	0.75

Drive Pin Adjustable Every 2 mm (.079 in)

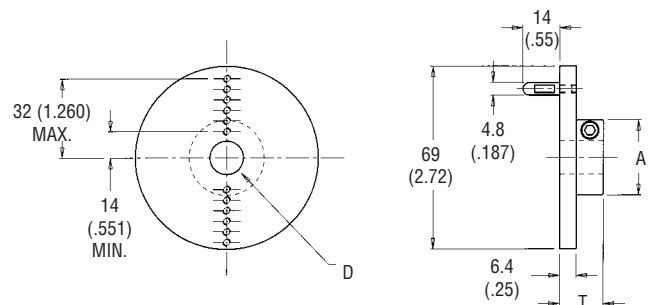

## 720 DRIVE PLATE

Multi-position pin with non marring clamp collar design.

Part #	D		A		T	
	mm	in	mm	in	mm	in
720-0100	25.40	1.000	44.5	1.75	20.6	0.81
720-0110	28.00	1.102	48.0	1.89	23.0	0.90
720-0125	31.75	1.250	52.3	2.06	20.6	0.81
720-0126	32.00	1.259	54.0	2.13	23.0	0.90
720-0137	34.93	1.375	57.2	2.25	22.1	0.87
720-0138	35.00	1.378	57.0	2.24	23.0	0.90
720-0142	36.00	1.417	57.0	2.24	23.0	0.90
720-0150	38.10	1.500	60.5	2.38	22.1	0.87

Drive Pin Adjustable Every 5 mm (.197 in)

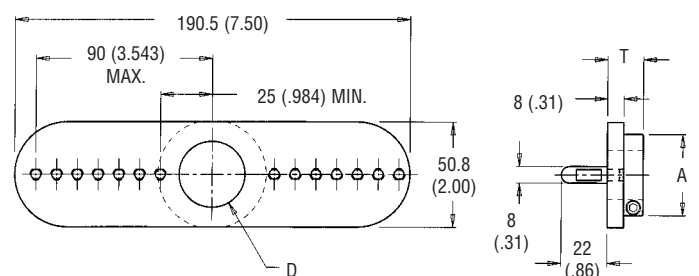

# Selection Criteria and Calculations

For every application determine the **TORQUE**, **MAXIMUM RPM**, and for brakes, the **BENDING MOMENT**. Then you can choose the correct shaft or coupling, and various accessories.

## Three Steps to Selection

### 1. TORQUE

The line tension multiplied by the radius of a full spool.

Example:

$$\begin{aligned} \text{Torque} &= \text{Full Spool Radius}(r) \times \text{Line Tension}(T) \\ &.15\text{m} \times 8 \text{ N} = 1.2 \text{ Nm} \\ &5.9 \text{ in} \times 1.8 \text{ lbs} = 10.6 \text{ in lbs} \end{aligned}$$

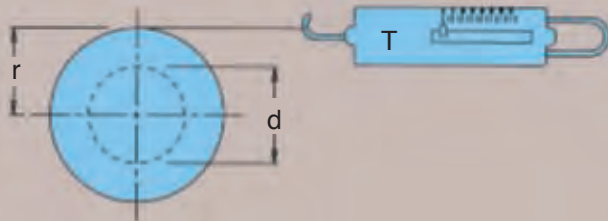

**Selection:** In this example Model 523 or larger will work.

### EXAMPLE SELECTION CRITERIA

Required Information	Example	
Line Tension (T)	8N	1.8 lbs.
Spool Weight (W)	134N	30 lbs.
Full Spool Radius (r)	.15m	5.9 in.
Spool Core Diameter(d)	.125m	.41 ft.
Spool Centerline Distance (L)	.11m	4.5 in.
Line Speed	90m/min.	295 ft/min

### 2. BENDING MOMENT

The total weight multiplied by the Spool Centerline Distance (L).

Example:

$$\begin{aligned} \text{Bending Moment} &= \text{Spool Weight (W)} \times \text{Spool Centerline Distance (L)} \\ &134\text{N} \times .11\text{m} = 14.7\text{Nm} \\ &30 \text{ lbs} \times 4.5 \text{ in} = 135 \text{ in lbs} \end{aligned}$$

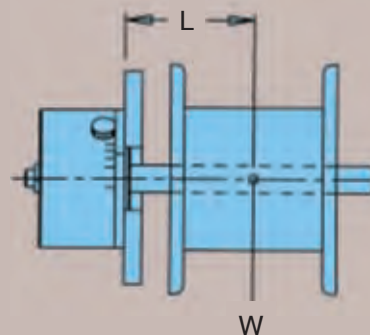

**Selection:** In this example Model 610 or larger will work.

### HANDY CONVERSION TABLES

Torque	To	Multiply By:	Force	To	Multiply By:	Length	To	Multiply By:	Velocity	To	Multiply By:
lbf. in.	Nm	0.113	lbf	N	4.448	in	mm	25.4	fps	m/s	0.305
ozf. in.	Nm	0.0071	kgf	N	9.807	in	m	0.0254	fpm	m/min	.305
lbf. ft.	Nm	1.356	gf	N	.009807	ft	m	0.305	m/min	f/min	3.281
kgf. m	Nm	9.807	N	lbf	0.225	mm	in	0.0394	m/s	fps	3.281
Ncm	Nm	0.01	N	kgf	0.102	m	in	39.370			
Nm	ibf. in.	8.850	N	gf	101.97	m	ft	3.280			
Nm	ozf. in.	141.60	kg	lbf	2.2046						
Nm	ibf. ft.	0.737	lbf	kg	.4536						
Nm	kgf. m	0.102									
Nm	Ncm	100.0									
			Temperature						Inertia	To	Multiply By:
			°C = (°F - 32) x $\frac{5}{9}$						kgm <sup>2</sup>	gcm <sup>2</sup>	10 <sup>7</sup>
									gcm <sup>2</sup>	oz in <sup>2</sup>	0.0054
									oz in <sup>2</sup>	gcm <sup>2</sup>	182.9

### 3. OPERATING CURVES

When a magnetic brake shaft is turning, mechanical energy is converted into thermal energy (watts). The amount of thermal energy (watts) is a function of the RPM and the TORQUE SETTING.

**CALCULATE MAX RPM:** Example calculation:

$$\text{Max RPM} = \frac{\text{Line Speed}}{\pi \times \text{Core Dia.}(d)} = \frac{90\text{m/min}}{3.14 \times .125\text{m}} = \frac{295 \text{ ft/min}}{3.14 \times .41 \text{ ft}} = 229 \text{ RPM}$$

With the torque calculated in (1) and the maximum RPM calculated in (3), refer to operating curves to determine if your application is within the safe operating range of the brake.

**Selection:** In this example, Model 523 or larger will work, however... CONSIDERING TORQUE, BENDING MOMENT AND MAX RPM, THE BEST CHOICE IS MODEL 610.

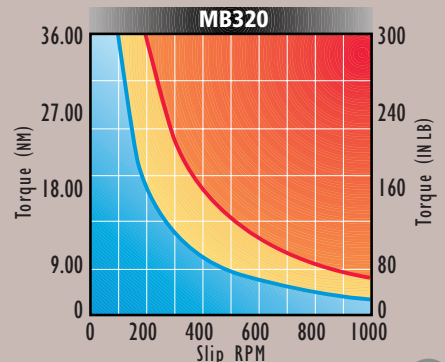
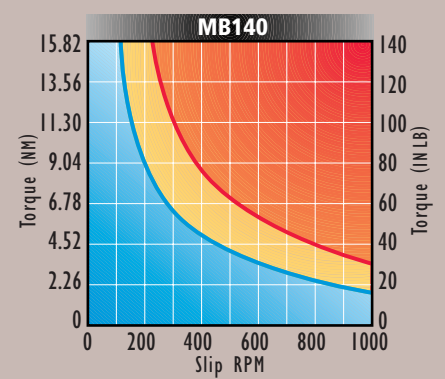
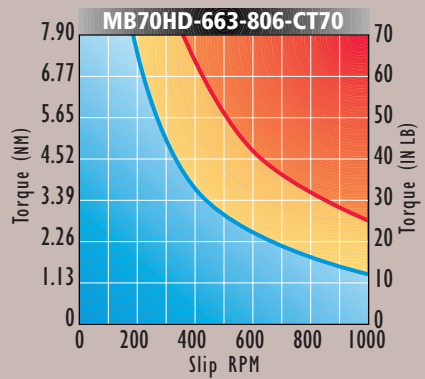
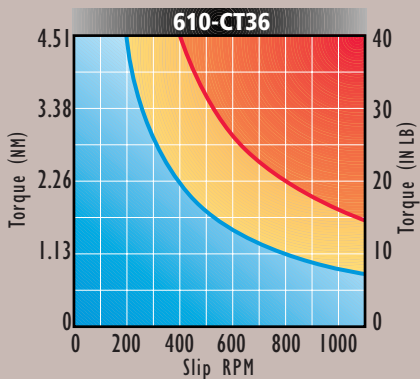
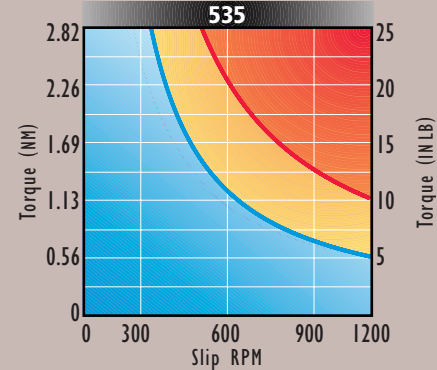
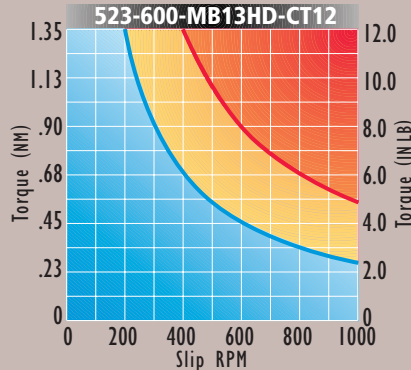
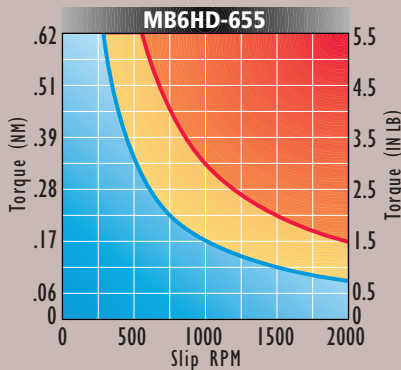
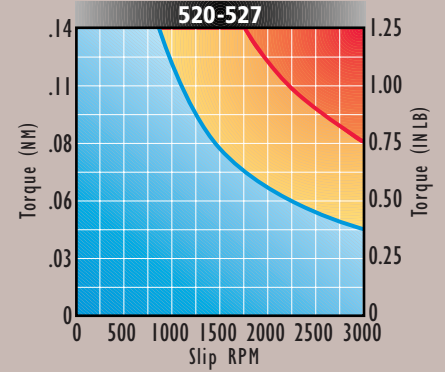
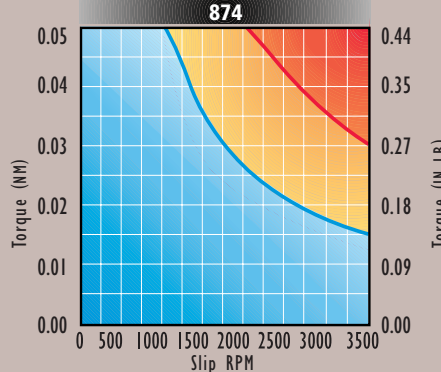
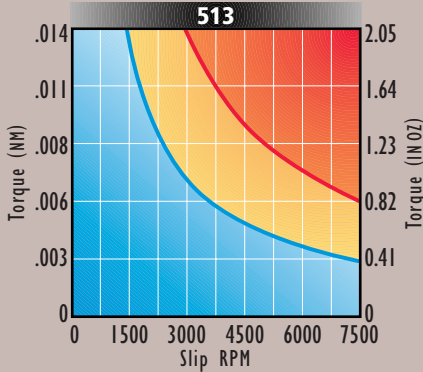

**HOW TO USE THE CURVES:** Find the slip RPM on the X axis and the torque on the Y axis. The blue area represents safe continuous duty. The area between the two curves (yellow) represents intermittent duty, such as, five minutes on, five minutes off. Operating above the red line for any period of time will cause overheating. This could damage the unit.



For Magnetic Brakes & Clutches we have the experience and know-how to improve your application!



Powered take-up: Two flanged bearings support shaft and the housing is powered.



Retrofit application using Model 523 and 700-002M Mounting Bracket on Twister.



Torque limiting application using Model 610 with custom adaptor and gear.



Tensioning films & foils. Model 527 with urethane "nib" roller.



Perfect for "flyer" type applications: adjustable, accurate and no electricity.

## Put Magnetic Technologies to work for you



Payoff application on roll of film cleaning material.



Tensioning Aramid Yarn using Model 523 with Spiked Drive Plate Assembly #750-034.



More torque in tight environments with a 3:1 gear ratio.